

Conveyor chain



RENOLD
Superior Chain Technology

Renold Chain Product Range



Roller Chain

- British, ANSI, API, DIN, ISO and Works Standard Chains
- Adapted Chains
- Extended Pitch Chains
- Hollow Pin Chains
- Made to Order, Special Chains
- Mini Pitch Chains
- Nickel Plated Chains
- Oilfield Chains
- Plastic Bush Chains
- Power and Free Chains
- Polymer Block Chains
- Side Bow Chains
- Stainless Steel Chains

Applications

- Abattoirs • Air Conditioning • Aircraft - Civil & Military • Bakery Machines • Battery Manufacturing
- Brewing • Canning • Carpet Machines • Chart Tables/Marine • Chocolate Manufacturing
- Concrete Moulding Equipment • Copying Machines • Dairy Machinery • Drying Machinery
- Earth Moving Equipment • Extrusion Machines • Filtration Plants • Food & Drink Manufacture
- Glass Manufacture • Health Care Equipment • Hydraulic Components • Ice-Cream Manufacture
- In-flight Refueling • Ingot Casting & Scrap Metal Processing • Latex Machinery • Laundry Machinery
- Lawnmower Manufacture • Mill Machinery • Mining • MOT Brake Testing Machinery • Nuclear Power
- Off Road Vehicles • Oil Industry • Packaging Machines • Paper & Card Making • Paper Shredders
- Plastic Machinery • Potato Grading Machinery • Power Generation • Printing Machines • Quarry Plant
- Road Making & Plant Machinery • Robotic Systems • Roof Tile Manufacture • Ship's Engines
- Silkscreen Machinery • Ski-Lifts • Soot Blowers • Steel Making • Straddle Carriers • Sugar Beet Machines • Sun-Blinds • Telecommunications • Textile Machinery • Timber and Woodworking Machines
- Tin Printer Ovens • Tobacco/Cigarette Machinery • Tunnelling Machines • T.V. and Audio Equipment
- Tyre Manufacture • Waste Handling • X-Ray Equipment

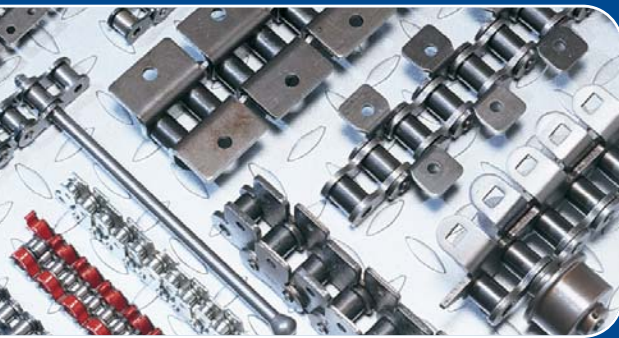

Conveyor Chain

- British, ISO and Works Standard Chains
- Adapted Chains
- Agricultural Chains
- Bakery Chains
- Deep Link Chains
- Escalator Chains
- Made to Order, Specials
- Stainless Steel Chains
- Sugar Cane Chains
- Zinc Plated Chains

Applications

- Abattoirs • Agricultural Machines • Bakery Machines • Bottle Washing Plants
- Brick & Tile Machinery OEM • Car Plants • Cement Plants • Chemical Plants • Chicken Process Equipment
- Cigarette/Tobacco Machinery • Dust Filters • Egg Sorting Conveyors • Electrical Switchgears • Escalators
- Extrusion Machines • Feed Mill Machines • Feed Silo Equipment • Fibreglass Industry • Filtration Plants
- Fish Conveyor • Food Sterilisation • Food Processing • Freezing Equipment • Freezing Tunnels • Glass Manufacturing • Grain Conveyor • Harvesting Machines • Ice Cream Machines • Induction Furnaces • Ingot Casting & Scrap Metal Processing Mfr • Latex Machinery • Leisure Rides • Luggage & Parcel Handling • Machine Tools • Mail Sorting • Metal Casting • Mushroom Compost Machinery • Nuclear • Ovens/Provers • Potato Grading Machinery • Potting Machinery • Quarries • Radio Astronomy • Roof Tile Manufacture • Rope Machinery • Saw Mill Equipment • Sewage Plants • Shaker Conveyors • Ski-Lifts • Sluice Gates • Steel Making • Sugar Factories • Swarf Conveyors • Textile Machinery • Timber & Woodworking Machines • Tool Changer • Tunnelling Machines • Tyre Manufacture • Washing & Sterilising Machines • Water Treatment • Wire Belts



Lifting Chain

- LH(BL), AL, LL and Works Standard Chains

Applications

- Bottle Washing Plants • Cement Plants • Chemical • Counterbalance Sets • Cranes
- Dust/Swarf Conveyors • Elevators • Food Processing • Food Sterilisation • Fork Lift Trucks
- Pipe Line Valves/Taps • Printing Machines • Rock Drilling • Straddle Carriers • Sun-Blinds • Tail Lifts

Table of Contents

Section 1 - Conveyor Products and Dimensions

Conveyor chain introduction	5-7
BS conveyor chain dimensions	8-9
BS rollers and connecting links	10
Extra strength conveyor chain	11-12
Extra strength rollers and connecting links	13
BS attachments	14-20
BS spigot pins	21
BS outboard rollers	22
ISO conveyor chain	23-27
ISO rollers	28
ISO connecting links	29
ISO attachments	30-34
Bucket Elevator chain	35-41
Welded Steel chain	42-43
Agricultural chain	44
Agricultural chain attachments	45
Agricultural chain - standard sprockets	46-47

Section 2 - Conveyor Sprocket Details

3000 lbf, 13000 Newton sprockets	49
4500 lbf, 20000 Newton sprockets	50
6000 lbf, 27000 Newton sprockets	50
7500 lbf, 33000 Newton sprockets	50
12000 lbf, 54000 Newton sprockets	51
15000 lbf, 67000 Newton sprockets	51
24000 lbf 107000 Newton sprockets	51
30000 lbf, 134000 Newton sprockets	51

Section 3 - Conveyor Chain Installation and Maintenance

Installation and Maintenance guidelines and advice	53-68
--	-------

Section 4 - Conveyor Chain Designer Guide

Specification guidelines and advice	70-109
-------------------------------------	--------

Section 5 - Industrial Applications and Special Engineered Chain

Examples of some specialist industries that benefit from Renold Conveyor Chain	111-135
--	---------

Section 1

Conveyor

Products & Dimensions

Conveyor Chain

Renold Ultimate Performance

Renold Ultimate Performance

- The performance of Renold Conveyor Chain is ensured by a programme of continuous testing and quality control of component dimensions, fits and material properties.
- Specially formulated lubricants reduce initial wear, provide corrosion protection and long storage life.
- Breaking loads exceed the minimum international standards.
- Correct chain selection is essential for optimum performance. Renold's experienced design team are always available to freely advise on particular products and applications.

Renold Ultimate Specification

The Renold specification has taken many years in design and development to achieve the optimum product. In order to ensure this is translated into product performance, we strictly control:

- Materials
- Heat Treatment
- Processes
- Fits
- Attachment Assembly
- Lubrication

Fatigue life is improved by maintaining precise fits and tolerances between the pins, bushes and side plates.



Chain and sprocket life are optimised by the rigid control of pitch accuracy, resulting in excellent gearing, lower friction, reduced wear and a reduction in noise levels during operation.

Exact control of bush projection through the chain side plate maintains precise clearances between the chain's inner and outer links. This feature reduces the risk of wear during operation, allows space for lubricant penetration, and greatly reduces the possibility of chain seizure in dusty/abrasive environments.

Bush and roller life are maximised by controlling the concentricity of these components and careful selection and control of the heat treatment process.

Down time in hostile environments is minimised by strict control of inner and outer plate clearances, ensuring effective lubricant penetration to the bearing surfaces.

Renold Ultimate Reliability

- The key to Renold chain reliability is consistency in design and manufacture.
- Maximum chain strength and resistance to wear are achieved by strict control of the material specification and by using state of the art heat treatment processes.
- The consistent overall tolerances of Renold chain make it ideal for conveying systems requiring precise alignment on multi-strand chain layouts.

Conveyor Chain Details

Conveyor Chain Types

Precision conveyor chain, like transmission chain, consists of a series of journal bearings held in precise relationship to each other by constraining link plates.

Each bearing consists of a bearing pin and bush on which the chain roller revolves. The bearing pin and bush are case-hardened to allow articulation under high pressures, and to contend with the load carrying pressure and gearing action imparted via the chain rollers.

There is, for each strength of conveyor chain, a range of pitches; the minimum pitch being governed by the need for adequate wheel tooth strength; the maximum pitch being normally dictated by plate and general chain rigidity. When required, the normal maximum pitch can be exceeded by the use of strengthening bushes between the link plates, and suitable gaps to clear the bushes must be provided in the wheel teeth.

INTERNATIONAL STANDARDS

Conveyor chain, like transmission chain, can be manufactured to a number of different international standards. The main standards available are:

BRITISH STANDARD - BS

This standard covers chain manufactured to suit the British market and markets where a strong British presence has dominated engineering design and purchasing. The standard is based on the original Renold Conveyor Chain design.

ISO STANDARD

Chain manufactured to ISO Standard is not interchangeable with BS or DIN Standard Chain. This standard has a wide acceptance in the European market, except in Germany. Chain manufactured to this standard is becoming more popular and is used extensively in the Scandinavian region.

HOLLOW BEARING PIN CHAIN

Hollow bearing pin type chain affords ready facility for fixing attachments to outer links by bolting through the hollow bearing pins and is suitable for use in all normal conditions.

The attachments may be bolted up tight or held in the hollow bearing pin in a "free" manner. Bolted attachments should only span the outer link, as a bolted attachment spanning the inner link would impair the free articulation of the chain.

DEEP LINK CHAIN

Deep Link chain has sideplates with a greater depth than the normal chain plates; thus providing a continuous carrying edge above the roller periphery. When lateral flexing of the chain is required to negotiate horizontal bend radii, coned bearing pins are employed.

Available in Hollow or Solid Pin versions.

SOLID BEARING PIN CHAIN

Solid bearing pin chain, while having exactly the same gearing dimensions, i.e. pitch, inside width and roller diameter as the equivalent hollow bearing pin chain, is more robust and is recommended for use where arduous conditions may be encountered.

CHAIN ROLLERS

In general, the use of chain incorporating rollers is recommended, but bush chain, i.e. chain without rollers, can be used on certain applications.

Rollers of the plain or flanged type, with a choice of size and material, are listed for most chain series - size and material being dependent upon the type of application.

HOLLOW BEARING PIN CHAIN

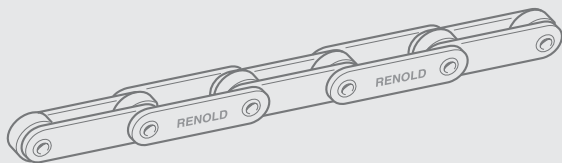

SOLID BEARING PIN CHAIN

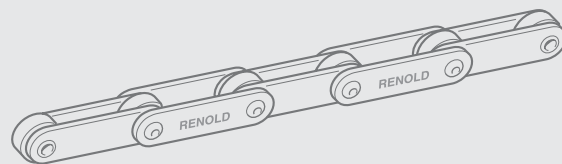

DEEP LINK CHAIN

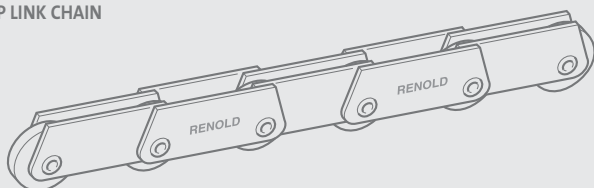

CHAIN ROLLERS

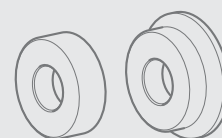

Standard Attachments

Standard attachments are parts fitted to a base chain to adapt it for a particular purpose as a conveying medium. Attachments may form an integral part of the link plate or may be built into the chain as a replacement of the normal link. Other attachments (according to type) are fixed to the chain plates by projection or fillet welding, to either one or both sides of the chain.

Standard attachments are described below:

- The letter stands for the attachment type.
- The figure stands for the number of holes within each attachment type.

Special attachments can be manufactured, but wherever possible, standard attachments used on our preferred range of chains shown earlier will give price and delivery advantages. Consult Renold Chain for details.

K Attachments Outer or Inner Links

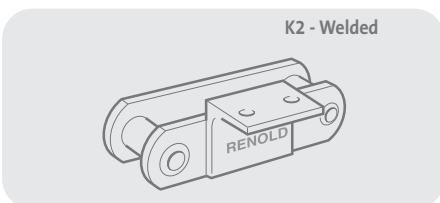
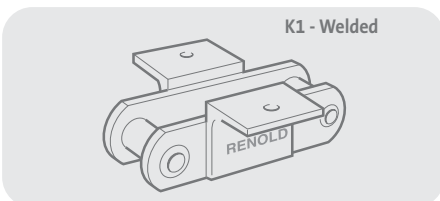
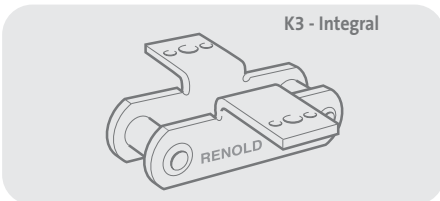
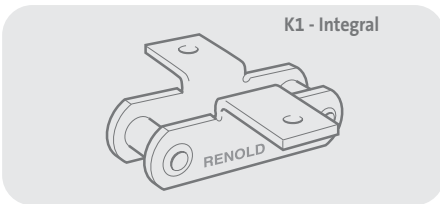

K Attachments provide a platform parallel to the chain line and bearing pin axis. They are used for securing slats, scrapers, buckets etc. to the chain.

F Attachments Outer or Inner Links

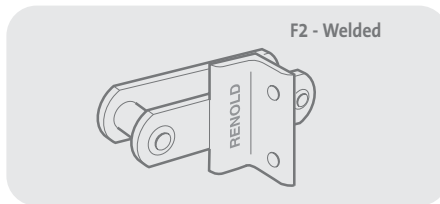
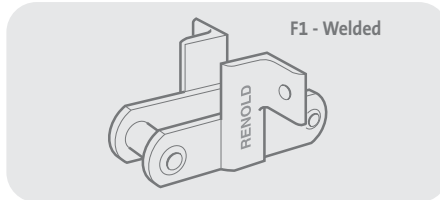

F Attachments provide a flat surface at right angles to the chain plate. They are used for securing pushers, scraper bars, etc.

L Attachments

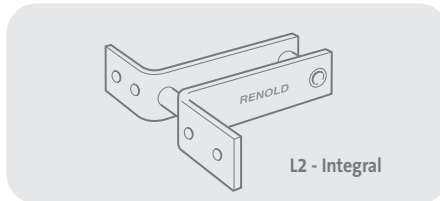
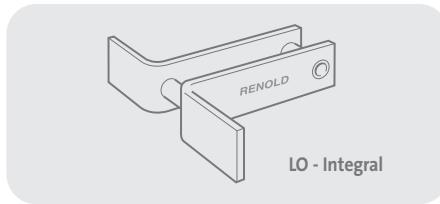

L Attachments are integral with the chain outer plates. Normally they have one or two holes (L2 preferred), but for use on scraper applications they can be supplied without holes and with various box widths (LO Type).

Outboard Rollers For use on Hollow Bearing Pin Chain

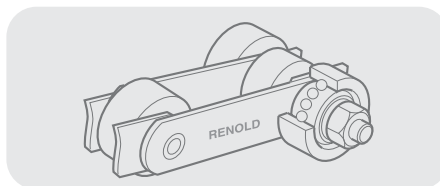

Outboard rollers have two principal advantages; as direct load carriers they enable the chain rollers to be used solely for gearing purposes and in the event of outboard roller wear, they can be replaced easily without recourse to chain replacement. They are particularly useful when attachments prevent the gearing rollers running on support tracks on the return run or where the roller loading is high.

Spigot Pins

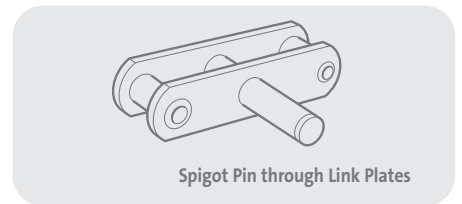
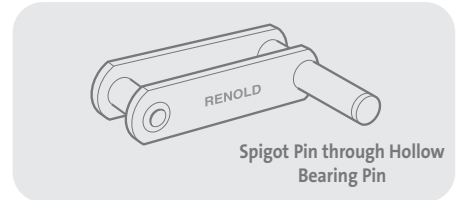

Spigot pins may be assembled either through hollow bearing pins or link plates and are secured by a nut and spring washer.

Holed Link Plates

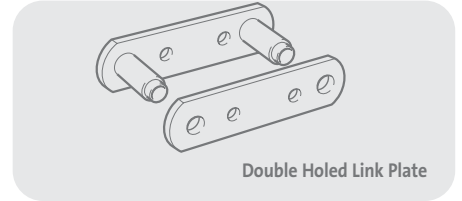
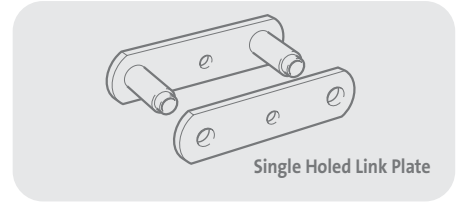

Single holing is primarily for use with spigot pins and is required on both sides of the chain. Double holing is provided for the assembly of special attachments on one or both sides of the chain. The holes in the inner plates are countersunk on the inside face to prevent the bolt heads fouling the sprocket teeth.

Standard Sprockets

A modified rim section is required when G or inverted F2 attachments are fitted to inner links.

Extended Bearing Pins

Extended bearing pins, one side of the chain, can be supplied hard, soft, solid or drilled and are similar to the spigot pin arrangement.

FOR ATTACHMENT SIZES AND ATTACHMENTS OTHER THAN THOSE SHOWN, CONSULT RENOLD CHAIN.

Standard Conveyor Chain

BS 4116 Part 4

Section 1

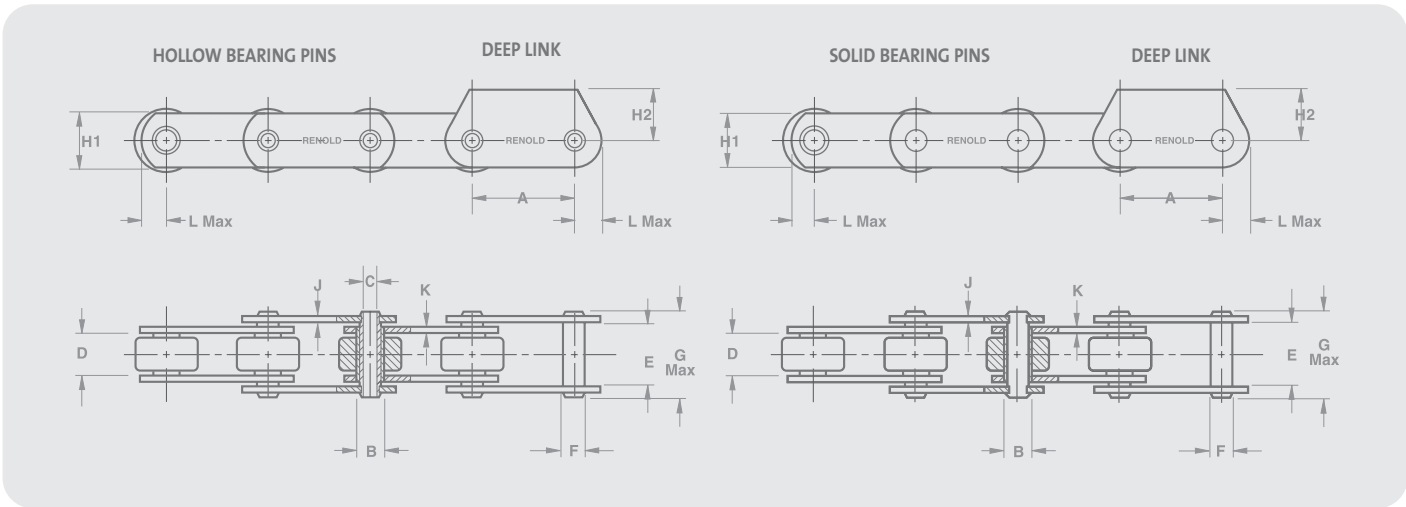

Hollow Bearing Pin

Chain Technical Details

Breaking Load (Min) lbf	Breaking Load (Min) Newtons	B.S Series Ref	Pitch Min Inch	Max Inch	Min mm	Max mm Max	Bush Dia Min	Hollow Bearing Pin Bore Dia Min	Inside Width Inner Min	Width Outer Min	Pin Dia Max	Len Max	Plate Height	Height	Width Outer	Width Inner	Head Max
			A	A	A	A	B	C	D	E	F	G	H1	H2	J	K	L
4500	20000	2H020	1.5	3.0	38.1	76.2	12.1	6.6	12.7	17.8	9.5	24.6	19.1	-	1.8	2.3	11.4
6000	27000	3H027	1.5	6.0	38.1	152.4	18.0	10.1	15.0	25.4	14.0	36.5	25.4	26.0	3.8	3.8	15.0
12000	54000	4H054	2.0	9.0	50.8	228.6	23.6	13.2	19.0	32.5	19.0	44.0	38.1	32.0	3.8	5.1	22.1
24000	107000	5H107	3.5	12.0	88.9	304.8	33.2	20.1	25.4	43.0	26.9	57.0	51.0	45.0	5.1	7.1	29.7
36000	160000	6H160	5.0	18.0	127.0	457.2	38.1	23.1	38.1	59.0	31.8	79.5	61.0	-	7.6	8.9	34.8

Solid Bearing Pin

Chain Technical Details

Breaking Load (Min) lbf	Breaking Load (Min) Newtons	B.S Series Ref	Pitch Min Inch	Max Inch	Min mm	Max mm Max	Bush Dia Min	Hollow Bearing Pin Bore Dia Min	Inside Width Inner Min	Width Outer Min	Pin Dia Max	Len Max	Plate Height	Height	Width Outer	Width Inner	Head Max
			A	A	A	A	B	C	D	E	F	G	H1	H2	J	K	L
3000	13000	1S013	1.0	4.5	25.4	114.3	8.6	-	11.7	16.0	5.7	21.8	18.0	16.0	1.8	1.8	11.4
7500	33000	3S033	1.5	6.0	38.1	152.4	18.0	-	15.0	25.4	14.0	38.0	25.4	26.0	3.8	3.8	15.0
15000	67000	4S067	2.0	9.0	50.8	228.6	23.6	-	19.0	32.5	19.0	46.0	38.1	32.0	3.8	5.1	22.1
30000	134000	5S134	3.5	12.0	88.9	304.8	33.2	-	25.4	43.0	26.9	60.0	51.0	45.0	5.1	7.1	29.7
45000	200000	6S200	5.0	18.0	127.0	457.2	38.1	-	38.1	59.0	31.8	82.0	61.0	-	7.6	8.9	34.8
60000	267000	7S267	6.0	18.0	152.4	457.2	38.1	-	38.1	59.0	23.0	80.0	61.0	-	7.6	8.9	34.8
90000	400000	8S400	6.0	24.0	152.4	609.6	38.1	-	38.1	66.3	29.4	94.0	63.5	-	10.0	13.0	35.8

THE DIMENSIONS LISTED WILL NOT VARY WITH PITCH SIZE FOR EACH GIVEN BREAKING LOAD.
 FOR THE DETAILS OF INDIVIDUAL PITCH SIZES, ROLLERS, AND SPARE LINKS, SEE PAGES 9 AND 10.
 FOR ATTACHMENTS SEE PAGES 14 - 22.

Standard and Deep Link Chain

BS4116 Part 4

Pitch Inch	mm	Roller Chain No Standard	Mass kg/m	Roller Chain No Deep link	Mass kg/m
---------------	----	-----------------------------------	--------------	------------------------------------	--------------

3000 lbf, 13000 Newtons Breaking Load - Solid Pin

1.0	25.4	140048/12	1.33	167048/12	1.62
1.5	38.1	140068/56	1.77	167068/56	2.03
2.0	50.8	140088/56	1.46	167088/56	1.70
2.5	63.5	140108/56	1.28	167108/56	1.52
3.0	76.2	140128/56	1.15	167128/56	1.37
3.5	88.9	140148/56	1.06	167148/56	1.28
4.0	101.6	140168/56	1.00	167168/56	1.22
4.5	114.3	140188/56	0.95	167188/56	1.18

4500 lbf, 20000 Newtons Breaking Load - Hollow Pin

1.5	38.1	198028**	2.00		
2.0	50.8	198030**	1.65	NOT	
2.5	63.5	198033**	1.46	AVAILABLE	
3.0	76.2	198039**	1.34		

6000 lbf, 27000 Newtons Breaking Load - Hollow Pin

1.5	38.1	105060/03*	2.94	107060/03	4.02
2.0	50.8	105080/12**	3.50	107080/12	4.52
2.5	63.5	105100/12	3.13	107100/12	4.10
3.0	76.2	105120/12**	2.88	107120/12	3.83
3.5	88.9	105140/12	2.71	107140/12	3.63
4.0	101.6	105160/12**	2.58	107160/12	3.49
4.5	114.3	105180/12	2.47	107180/12	3.36
5.0	127.0	105200/12	2.39	107200/12	3.27
6.0	152.4	105240/12**	2.27	107240/12	3.14

7500 lbf, 33000 Newtons Breaking Load - Solid Pin

1.5	38.1	145060/03*	3.54	167060/03	4.62
2.0	50.8	145080/12**	3.95	167080/12	4.97
2.5	63.5	145100/12	3.49	167100/12	4.46
3.0	76.2	145120/12**	3.19	167120/12	4.14
3.5	88.9	145140/12	2.97	167140/12	3.89
4.0	101.6	145160/12**	2.80	167160/12	3.71
4.5	114.3	145180/12	2.67	167180/12	3.56
5.0	127.0	145200/12	2.57	167200/12	3.45
6.0	152.4	145240/12*	2.42	167240/12	3.29

12000 lbf, 54000 Newtons Breaking Load - Hollow Pin

2.0	50.8	105081/03*	5.23	107081/03	6.25
3.0	76.2	105121/12**	6.93	107121/12	7.90
3.5	88.9	105141/12	6.35	107141/12	7.30
4.0	101.6	105161/12**	5.91	107161/12	6.85
4.5	114.3	105181/12	5.57	107181/12	6.50
5.0	127.0	105201/12	5.30	107201/12	6.22
6.0	152.4	105241/12**	4.89	107241/12	5.80
7.0	177.8	105281/12	4.60	107281/12	5.50
8.0	203.2	105321/12	4.39	107321/12	5.28
9.0	228.6	105361/12	4.21	107361/12	5.10

15000 lbf, 67000 Newtons Breaking Load - Solid Pin

2.0	50.8	145081/03*	6.28	167081/03	7.31
3.0	76.2	145121/12**	7.62	167121/12	8.59
3.5	88.9	145141/12	6.95	167141/12	7.90
4.0	101.6	145161/12**	6.43	167161/12	7.37
4.5	114.3	145181/12	6.03	167181/12	6.96
5.0	127.0	145201/12	5.72	167201/12	6.64
6.0	152.4	145241/12**	5.24	167241/12	6.15
7.0	177.8	145281/12	4.90	167271/12	5.80
8.0	203.2	145321/12	4.65	167321/12	5.54
9.0	228.6	145361/12	4.44	167361/12	5.33

Pitch Inch	mm	Roller Chain No Standard	Mass kg/m	Roller Chain No Deep link	Mass kg/m
---------------	----	-----------------------------------	--------------	------------------------------------	--------------

24000 lbf, 107000 Newtons Breaking Load - Hollow Pin

4.0	101.6	105162/12**	12.74	107162/12	14.86
5.0	127.0	105202/12	11.21	107202/12	13.26
6.0	152.4	105242/12**	10.91	107242/12	12.91
7.0	177.8	105282/12	9.46	107282/12	11.42
8.0	203.2	105322/12	8.92	107322/12	10.86
9.0	228.6	105362/12	8.50	107362/12	10.42
12.0	304.8	105482/12	7.65	107482/12	9.52

30000 lbf, 134000 Newtons Breaking Load - Solid Pin

4.0	101.6	145162/12**	14.22	167162/12	16.34
5.0	127.0	145202/12	12.40	167202/12	14.45
6.0	152.4	145242/12**	11.18	167242/12	13.18
7.0	177.8	145282/12	10.31	167282/12	12.27
8.0	203.2	145322/12	9.66	167322/12	11.60
9.0	228.6	145362/12	9.16	167362/12	11.08
12.0	304.8	145482/12	8.14	167482/12	10.01

36000 lbf, 160000 Newtons Breaking Load - Hollow Pin

5.0	127.0	105203/12	24.97		
6.0	152.4	105243/12	22.18		
7.0	177.8	105283/12	20.18		
7.5	190.5	105303/12	19.40	AVAILABLE	
8.0	203.2	105323/12	18.68	ON	
9.0	228.6	105363/12	17.52	REQUEST	
12.0	304.8	105483/12	15.19		
15.0	381.0	105603/12	13.79		
18.0	457.2	105723/12	12.86		

45000 lbf, 200000 Newtons Breaking Load - Solid Pin

5.0	127.0	145203/12	27.34		
6.0	152.4	145243/12	24.15		
7.0	177.8	145283/12	21.87		
7.5	190.5	145303/12	20.98	AVAILABLE	
8.0	203.2	145323/12	20.15	ON	
9.0	228.6	145363/12	18.83	REQUEST	
12.0	304.8	145483/12	16.17		
15.0	381.0	145603/12	14.58		
18.0	457.2	145723/12	13.52		

60000 lbf, 267000 Newtons Breaking Load - Solid Pin

6.0	152.4	145245/12	23.38		
7.0	177.8	145285/12	21.64		
8.0	203.2	145325/12	19.96	AVAILABLE	
9.0	228.6	145365/12	18.66	ON	
12.0	304.8	145485/12	16.04	REQUEST	
15.0	381.0	145605/12	14.47		
18.0	457.2	145725/12	13.43		

90000 lbf, 400000 Newtons Breaking Load - Solid Pin

6.0	152.4	145247/12	29.09		
9.0	228.6	145367/12	23.36		
12.0	304.8	145487/12	20.50	AVAILABLE	
15.0	381.0	145607/12	18.78	ON	
18.0	457.2	145727/12	17.63	REQUEST	
24.0	609.6	145967/12	16.19		

* BUSH CHAIN ONLY

** PREFERRED SIZES OF CHAIN, WITH STANDARD SPROCKETS AND ATTACHMENTS AVAILABLE

THIS TABLE INDICATES STANDARD ROLLER CHAIN CONFIGURATIONS. WHERE ALTERNATIVE ROLLERS ARE REQUIRED, AMEND THE ROLLER SUFFIX FOR IDENTIFICATION PURPOSES WHEN ORDERING - SEE PAGE 10. FOR ROLLER SELECTION PROCEDURE - SEE PAGE 76.

Conveyor Chain

Rollers and Connecting Links

Section 1

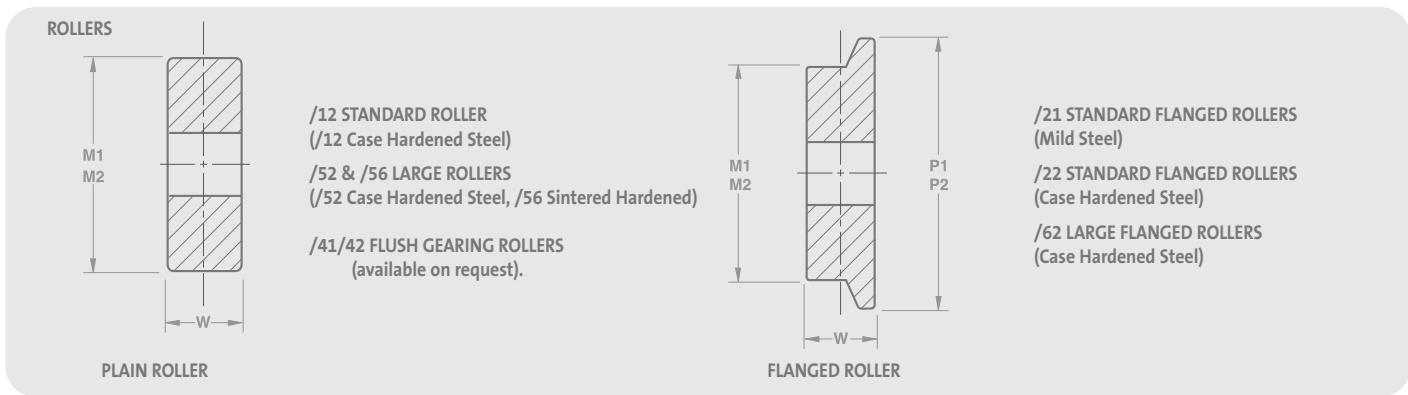

STANDARD ROLLER Breaking Load

STANDARD PLAIN

STANDARD FLANGED

Rollers				Min Pitch Inch	Min Pitch mm	Tread Dia	Roller Width	Rollers Available	Min Pitch Inch	Min Pitch mm	Dia	Tread Dia	Flange Width	Roller Available
Hollow Pin		Solid Pin												
lbf	Newtons	lbf	Newtons			M1	W				M1	P1	W	
-	-	3000	13000	1.0	25.4	12.1	11.4	/12	-	-	-	-	-	-
6000	27000	7500	33000	2.0	50.8	31.8	14.0	/12	2.5	63.5	31.8	41.3	14.0	/21 /22
12000	54000	15000	67000	3.0	76.2	47.6	17.8	/12	3.5	88.9	47.6	60.3	17.8	/21 /22
24000	107000	30000	134000	4.0	101.6	66.7	24.0	/12	4.5	114.3	66.7	85.7	24.0	/21 /22
36000	160000	45000	200000	5.0	127.0	88.9	36.8	/12	6.0	152.4	88.9	114.3	36.8	/22
-	-	60000	267000	5.0	127.0	88.9	36.8	/12	6.0	152.4	88.9	114.3	36.8	/22
-	-	90000	400000	6.0	152.4	88.9	36.8	/12	6.5	165.1	88.9	114.3	36.8	/22

LARGE ROLLER

PLAIN

FLANGED

Rollers				Min Pitch Inch	Min Pitch mm	Tread Dia	Roller Width	Rollers Available	Min Pitch Inch	Min Pitch mm	Dia	Tread Dia	Flange Width	Roller Available
Hollow Pin		Solid Pin												
lbf	Newtons	lbf	Newtons			M2	W				M2	P2	W	
-	-	3000	13000	1.5	38.1	25.4	11.4	/56	-	-	-	-	-	-
4500	20000	-	-	1.5	38.1	25.4	11.4	-	-	-	-	-	-	-
36000	160000	45000	200000	8.0	203.2	127.0	36.8	/52	9.0	228.6	127.0	152.4	36.8	/62
-	-	60000	267000	8.0	203.2	127.0	36.8	/52	9.0	228.6	127.0	152.4	36.8	/62
-	-	90000	400000	8.0	203.2	127.0	36.8	/52	9.0	228.6	127.0	152.4	36.8	/62

ROLLER SELECTION DETAILS - SEE PAGE 73.

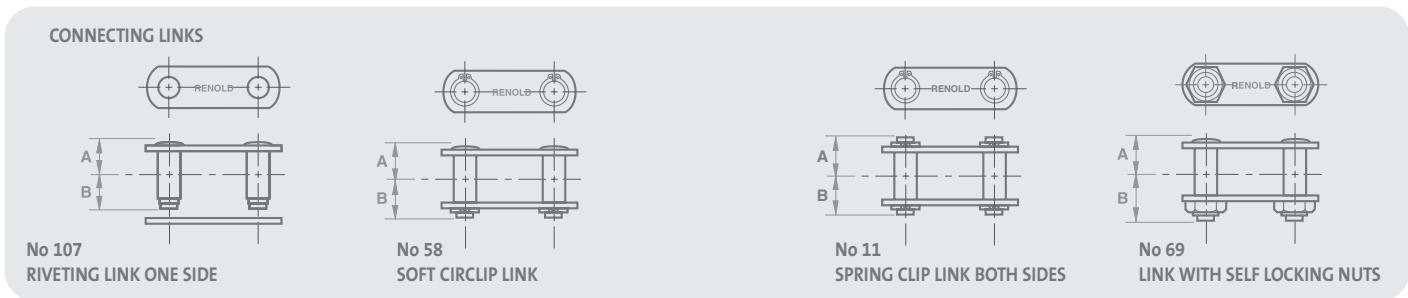

Chain

Breaking Load				No 107		No 58 Chain Centre to		No 11 Chain Centre to		No 69 Chain Centre to	
Hollow Pin		Solid Pin		Hollow Pin Both	Solid Pin Both	Plain Side	Fastener Side	Plain Side	Fastener Side	Plain Side	Fastener Side
lbf	Newtons	lbf	Newtons	A&B	A&B	A	B	A	B	A	B
-	-	3000	13000	-	11.0	11.0	13.0	-	-	11.0	17.0
4500	20000	-	-	12.3	-	-	-	13.8	13.8	-	-
6000	27000	7500	33000	18.3	19.0	19.0	22.0	-	-	19.0	30.0
12000	54000	15000	67000	22.0	23.0	23.0	25.0	-	-	23.0	36.0
24000	107000	30000	134000	28.5	30.0	-	-	-	-	30.0	46.0
36000	160000	45000	200000	39.8	41.0	-	-	-	-	41.0	62.0
-	-	60000	267000	-	40.0	-	-	-	-	40.0	56.0
-	-	90000	400000	-	47.0	-	-	-	-	47.0	68.0

DIMENSIONS 'A' & 'B' ARE MAXIMUM SIZES.

Extra Strength Standard Conveyor Chain

BS 4116 Part 4

Product Description

To complement our standard range of British Standard Conveyor Chain, this extra strength chain is more suitable for conveyor applications selected on ultimate tensile strength (breaking load). Each chain is the same dimensionally as its normal counterpart, for example an extra strength 24000 lbs chain has basically the same dimensions as a normal 12000 lbs series chain.

This chain is used extensively in the conveying of animal feed and bulk food stuffs such as grain, maize, wheat and raw food mixtures. Most of these applications use scraper type conveyor systems that normally have long centre distances between sprockets. Such systems are sometimes slow moving with little or no shock loading.

Contact our technical sales staff for selection and applicational details.

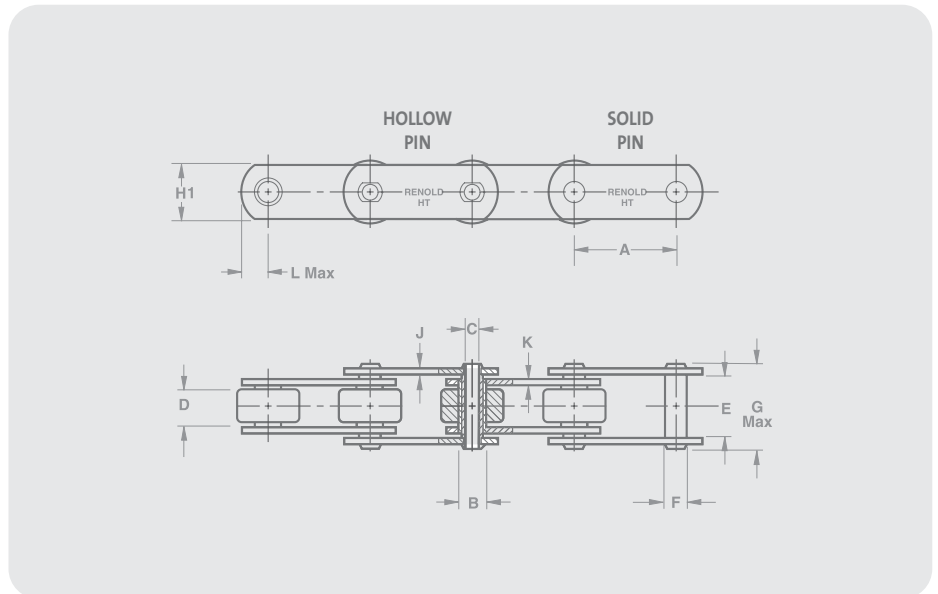

Hollow Bearing Pin - Extra Strength

Breaking Load (Min)		Pitch Min	Pitch Max	Pitch Min	Pitch Max	Bush Dia	Hollow Bearing Pin Bore Dia Min	Inside Width Inner Min	Width Outer Min	Pin Dia Max	Pin Len Max	Plate Height	Plate Width Outer	Plate Width Inner	Plate Head Max
lbf	Newtons	Inch	Inch	mm	mm	Max	Min	Min	Min	Max	Max		Outer	Inner	Max
		A	A	A	A	B	C	D	E	F	G	H1	J	K	L
12000	54000	1.5	6.0	38.1	152.4	18.0	10.1	15.0	25.4	14.0	36.5	25.4	3.8	4.0	15.0
24000	107000	2.0	9.0	50.8	228.6	23.6	13.2	19.0	32.5	19.0	44.0	38.1	3.8	5.1	22.1
48000	213500	3.5	12.0	88.9	304.8	33.2	20.1	25.4	43.0	26.9	57.0	51.0	5.1	7.1	29.7

Solid Bearing Pin - Extra Strength

Breaking Load (Min)		Pitch Min	Pitch Max	Pitch Min	Pitch Max	Bush Dia	Hollow Bearing Pin Bore Dia Min	Inside Width Inner Min	Width Outer Min	Pin Dia Max	Pin Len Max	Plate Height	Plate Width Outer	Plate Width Inner	Plate Head Max
lbf	Newtons	Inch	Inch	mm	mm	Max	Min	Min	Min	Max	Max		Outer	Inner	Max
		A	A	A	A	B	C	D	E	F	G	H1	J	K	L
15000	67000	1.5	6.0	38.1	152.4	18.0	-	15.0	25.4	14.0	38.0	25.4	3.8	4.0	15.0
30000	134000	2.0	9.0	50.8	228.6	23.6	-	19.0	32.5	19.0	46.0	38.1	3.8	5.1	22.1
60000	267000	3.5	12.0	88.9	304.8	33.2	-	25.4	43.0	26.9	60.0	51.0	5.1	7.1	29.7

THE DIMENSIONS LISTED WILL NOT VARY WITH PITCH SIZE FOR EACH GIVEN BREAKING LOAD.
 FOR THE DETAILS OF INDIVIDUAL PITCH SIZES, ROLLERS, AND SPARE LINKS, SEE PAGES 12 AND 13.
 EXTRA STRENGTH CHAINS ARE BASED ON THE STANDARD CHAIN SHOWN ON PAGE 8.
 FOR ATTACHMENTS SEE PAGES 14 - 22.

Extra Strength Conveyor Chain

Standard Range - B.S.

Pitch Inch	mm	Roller Chain No Extra Strength	Mass kg/m
---------------	----	---	--------------

12000 lbf, 54000 Newtons Breaking Load - Hollow Pin
(Extra strength version of 6000 lbf series)

1.5	38.1	102060/03*	2.94
2.0	50.8	102080/12**	3.50
2.5	63.5	102100/12	3.13
3.0	76.2	102120/12**	2.88
3.5	88.9	102140/12	2.71
4.0	101.6	102160/12**	2.58
4.5	114.3	102180/12	2.47
5.0	127.0	102200/12	2.39
6.0	152.4	102240/12**	2.27

15000 lbf, 67000 Newtons Breaking Load - Solid Pin
(Extra strength version of 7500 lbf series)

1.5	38.1	162060/03	3.54
2.0	50.8	162080/12**	3.95
2.5	63.5	162100/12	3.49
3.0	76.2	162120/12**	3.19
3.5	88.9	162140/12	2.97
4.0	101.6	162160/12**	2.80
4.5	114.3	162180/12	2.67
5.0	127.0	162200/12	2.57
6.0	152.4	162240/12**	2.42

24000 lbf, 107000 Newtons Breaking Load - Hollow Pin
(Extra strength version of 12000 lbf series)

2.0	50.8	102081/03	5.23
3.0	76.2	102121/12**	6.93
3.5	88.9	102141/12	6.35
4.0	101.6	102161/12**	5.91
4.5	114.3	102181/12	5.57
5.0	127.0	102201/12	5.30
6.0	152.4	102241/12**	4.89
7.0	177.8	102281/12	4.60
8.0	203.2	102321/12	4.39
9.0	228.6	102361/12	4.21

30000 lbf, 134000 Newtons Breaking Load - Solid Pin
(Extra strength version of 15000 lbf series)

2.0	50.8	162081/03	6.28
3.0	76.2	162121/12**	7.62
3.5	88.9	162141/12	6.95
4.0	101.6	162161/12**	6.43
4.5	114.3	162181/12	6.03
5.0	127.0	162201/12	5.72
6.0	152.4	162241/12**	5.24
7.0	177.8	162281/12	4.90
8.0	203.2	162321/12	4.65
9.0	228.6	162361/12	4.44

* BUSH CHAIN ONLY.

** PREFERRED SIZES OF CHAIN, WITH STANDARD SPROCKETS AND ATTACHMENTS AVAILABLE.

Pitch Inch	mm	Roller Chain No Extra Strength	Mass kg/m
---------------	----	---	--------------

48000 lbf, 2135000 Newtons Breaking Load - Hollow Pin
(Extra strength version of 24000 lbf series)

3.5	88.9	102142/03	8.20
4.0	101.6	102162/12**	12.74
5.0	127.0	102202/12	11.21
6.0	152.4	102242/12**	10.91
7.0	177.8	102282/12	9.46
8.0	203.2	102322/12	8.92
9.0	228.6	102362/12	8.50
12.0	304.8	102482/12	7.65

60000 lbf, 267000 Newtons Breaking Load - Solid Pin
(Extra strength version of 30000 lbf series)

3.5	88.9	162142/12	9.90
4.0	101.6	162162/12**	14.22
5.0	127.0	162202/12	12.40
6.0	152.4	162242/12**	11.18
7.0	177.8	162282/12	10.31
8.0	203.2	162322/12	9.66
9.0	228.6	162362/12	9.16
12.0	204.8	162482/12	8.14

THIS TABLE INDICATES STANDARD ROLLER CHAIN CONFIGURATIONS. WHERE ALTERNATIVE ROLLERS ARE REQUIRED, AMEND THE ROLLER SUFFIX FOR IDENTIFICATION PURPOSES WHEN ORDERING - SEE PAGE 13. FOR ROLLER SELECTION PROCEDURE SEE PAGE 76.

Extra Strength Conveyor Chain

Rollers and Connecting Links

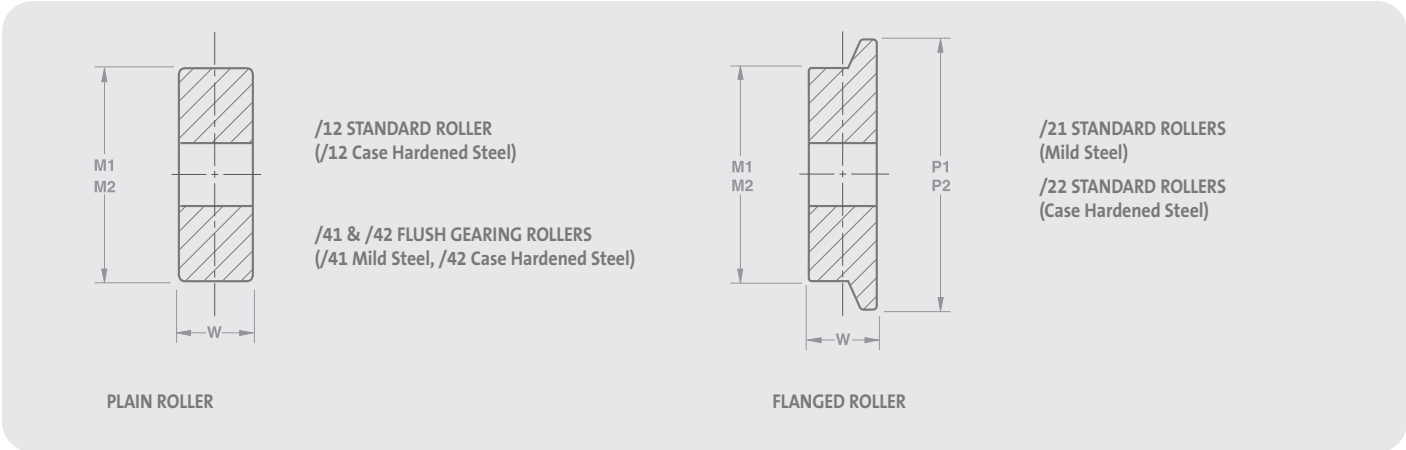

STANDARD ROLLER Breaking Load (min)

STANDARD PLAIN

STANDARD FLANGED

Rollers				Min Pitch Inch	Min Pitch mm	Tread Dia	Roller Width	Rollers Available	Min Pitch Inch	Min Pitch mm	Dia	Tread Dia	Flange Width	Roller Available
Hollow Pin		Solid Pin												
lbf	Newtons	lbf	Newtons											
						M1	W				M1	P1	W	
12000	54000	15000	67000	2.0	50.8	31.8	14.0	/12	2.5	63.5	31.8	41.3	14.0	/21 /22
24000	107000	30000	84000	3.0	76.2	47.6	17.8	/12	3.5	88.9	47.6	60.3	17.8	/21 /22
48000	213500	60000	200000	4.0	101.6	66.7	24.0	/12	4.5	114.3	66.7	85.7	24.0	/21 /22

ROLLER SELECTION DETAILS - SEE PAGE 76.

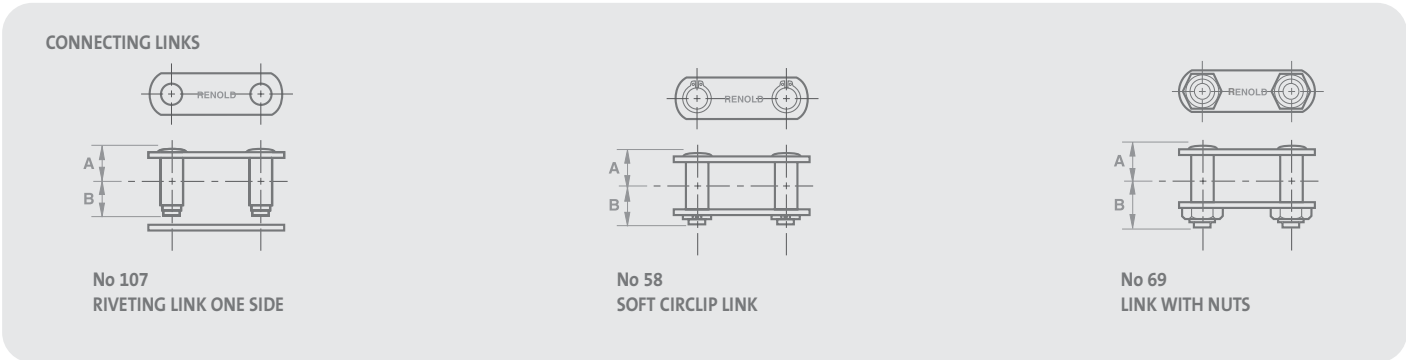

Chain	Breaking Load				No 107		No 58 Chain Centre to		No 11 Chain Centre to		No 69 Chain Centre to	
	Hollow Pin		Solid Pin		Hollow Pin Both	Solid Pin Both	Plain Side	Fastener Side	Plain Side	Fastener Side	Plain Side	Fastener Side
	lbf	Newtons	lbf	Newtons	A&B	A&B	A	B	A	B	A	B
	12000*	54000	15000*	67000	18.3	19.0	19.0	22.0	-	-	19.0	30.0
	24000*	107000	30000*	134000	22.0	23.0	23.0	25.0	-	-	23.0	36.0
	45000*	213500	60000*	267000	28.5	30.0	-	-	-	-	30.0	46.0

DIMENSIONS 'A' & 'B' ARE MAXIMUM SIZES.
FOR STANDARD VERSIONS OF THESE CHAINS SEE PAGE 8.
SMALL ROLLERS - AVAILABLE ON REQUEST

Conveyor Chain

BS K Attachments (Integral)

Section 1

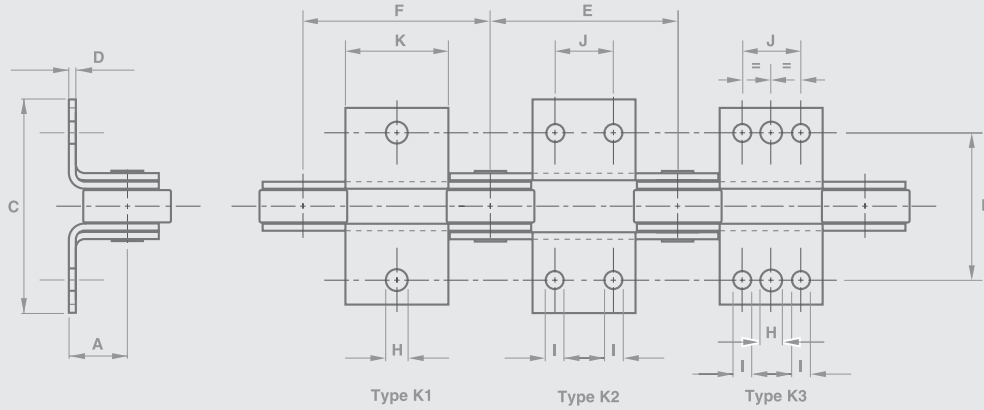

Chain Technical Details

Breaking Load lbf	Platform Height	Transverse Pitch	Width Over Attachment Inner/Outer	Attachment Thickness Inner/Outer	Attachment Type	Chain Pitch Outer	Chain Pitch Inner	Centre Hole Dia	Outer Holes Dia	Attachment Hole Pitch	Platform Length	Mass (kg/Att)
	A	B	C	D		E	F	H	I	J	K	
3000	16.5	44.5	66 / 70	1.8 / 1.8	K1	38.1	38.1	9.2	-	-	19.0	0.009
					K3	50.8	50.8	9.2	7.4	25.4	44.5	0.018
					K3	76.2	76.2	9.2	7.4	25.4	44.5	0.018
					K3	101.6	101.6	9.2	7.4	25.4	70.0	0.027
6000 / 7500	19.0	76.2	106 / 115	3.8 / 3.8	K3	76.2	76.2	10.5	9.2	22.2	43.0	0.045
					K3	101.6	101.6	10.5	9.2	31.8	63.5	0.077
					K3	127.0	127.0	10.5	9.2	57.2	89.0	0.109
					K3	152.4	152.4	10.5	9.2	57.2	114.5	0.141
12000 / 15000	31.8	89.0	130 / 136	5.1 / 3.8	K3	76.2	76.2	13.7	10.5	31.8	63.5	0.127
					K3	101.6	101.6	13.7	10.5	31.8	63.5	0.127
					K3	152.4	152.4	13.7	10.5	57.2	114.5	0.240
24000 / 30000	38.0	108.0	146 / 157	7.1 / 5.1	K1	101.6	101.6	15.3	-	-	56.0	0.172
					K2	101.6	101.6	-	12.2	31.8	56.0	0.172
					K3	152.4	152.4	15.3	12.2	57.2	107.0	0.318
36000 / 45000	50.8	146.0	198 / 198	8.9 / 7.6	K2	152.4	152.4	-	13.7	31.8	74.0	0.310
					K2	203.2	203.2	-	13.7	88.9	125.0	0.420

Conveyor Chain

BS K Attachments (Welded)

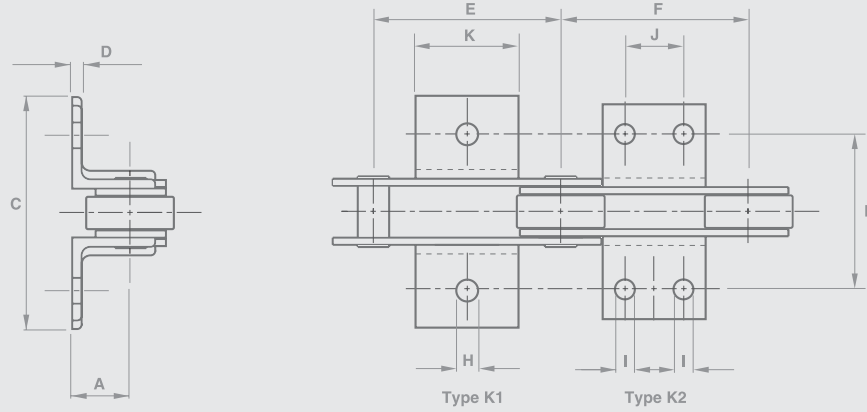

Chain Technical Details

Breaking Load lbf	Platform Height	Transverse Pitch	Width Over Attachment Inner/Outer	Attachment Thickness	Attachment Type	Attachment Minimum Outer Pitch	Attachment Minimum Inner Pitch	Centre Hole Dia	Outer Holes Dia	Attachment Hole Pitch	Platform Length	Mass (kg/Att)
	A	B	C (Max)	D		E	F	H	I	J	K	
3000	16.5	44.5	68 / 72	3.0	K1	38.1	50.8	8.2	-	-	19.0	0.027
					K1	50.8	63.5	8.2	-	-	38.0	0.059
					K2	50.8	63.5	-	7.4	22.2	38.0	0.059
					K2	76.2	76.2	-	7.4	25.4	44.5	0.068
6000 / 7500	19.0	76.2	106 / 116	4.0	K1	50.8	63.5	10.6	-	-	19.0	0.028
					K1	63.5	76.2	10.6	-	-	28.0	0.054
					K1	88.9	101.6	10.6	-	-	56.0	0.104
					K2	88.9	101.6	-	9.2	31.8	56.0	0.104
12000 / 15000	31.8	88.9	122 / 133	5.0	K2	114.3	127.0	-	9.2	57.2	84.0	0.163
					K1	76.2	88.9	13.7	-	-	35.0	0.119
					K1	88.9	101.6	13.7	-	-	56.0	0.193
					K2	88.9	101.6	-	10.5	31.8	56.0	0.193
24000 / 30000	38.0	108.0	146 / 159	6.0	K2	114.3	152.4	-	10.5	57.2	84.0	0.289
					K2	152.4	177.8	-	10.5	88.9	127.0	0.443
					K1	127.0	127.0	15.3	-	-	56.0	0.299
					K2	127.0	127.0	-	12.2	31.8	56.0	0.299
36000 / 45000 / 60000	50.8	146.0	202 / 200	8.0	K2	152.4	152.4	-	12.2	57.2	84.0	0.449
					K2	177.8	177.8	-	12.2	69.9	108.0	0.581
					K2	203.2	203.2	-	12.2	88.9	127.0	0.685
					K2	228.6	228.6	-	12.2	133.4	168.0	0.907
90000	57.0	171.5	229 / 252	10.0	K1	152.4	152.4	16.9	-	-	70.0	0.581
					K2	152.4	152.4	-	13.7	38.1	70.0	0.581
					K2	203.2	203.2	-	13.7	76.2	112.0	0.930
					K2	228.6	228.6	-	13.7	88.9	152.0	1.270
90000	57.0	171.5	229 / 252	10.0	K2	304.8	304.8	-	13.7	165.1	229.0	1.905
					K1	228.6	228.6	19.7	-	-	89.0	1.050
					K2	228.6	228.6	-	19.7	44.5	89.0	1.050
					K2	228.6	228.6	-	19.7	88.9	152.0	1.810
K2	304.8	304.8	-	19.7	165.1	229.0	2.710					

Conveyor Chain

BS F1 Attachments (Welded)

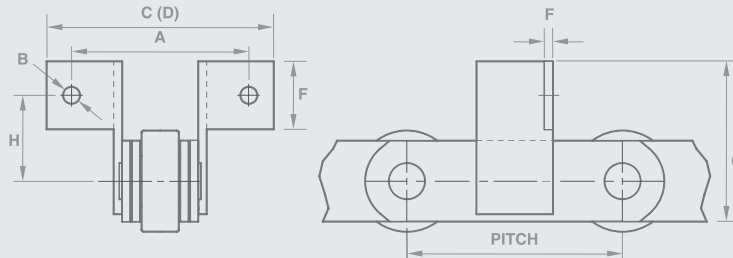

Chain Technical Details F1 Attachments

Breaking Load lbf	Minimum Pitch Inner Plate	Minimum Pitch Outer Plate	Transverse Pitch	Attachment Hole Size	Width Over Attachment Outer Plate	Width Over Attachment Inner Plate	Attachment Thickness	Attachment Face Height	Total Height of Attachment	Attachment Hole Distance From Chain Centreline	Mass (kg)
			A	B	C (Max)	D (Max)	E	F	G	H	
3000	50.8	38.1	44.5	7.4	72.0	68.0	3.0	19.0	44.5	26.0	0.054
6000 / 7500	69.9	57.2	76.2	9.2	116.0	106.0	4.0	25.4	56.0	32.4	0.082
12000 / 15000	101.6	82.6	88.9	10.5	133.0	122.0	5.0	31.8	84.0	51.4	0.163
24000 / 30000	139.7	114.3	108.0	12.2	159.0	146.0	6.0	44.5	108.0	63.5	0.435
36000 / 45000	165.1	133.4	146.0	13.7	200.0	202.0	8.0	63.5	152.0	90.0	0.954
60000	165.1	133.4	146.0	13.7	200.0	202.0	8.0	63.5	152.0	90.0	0.950
90000	190.5	152.4	171.5	19.7	252.0	229.0	10.0	63.5	152.0	88.9	1.530

Conveyor Chain

BS F2 Attachments (Welded)

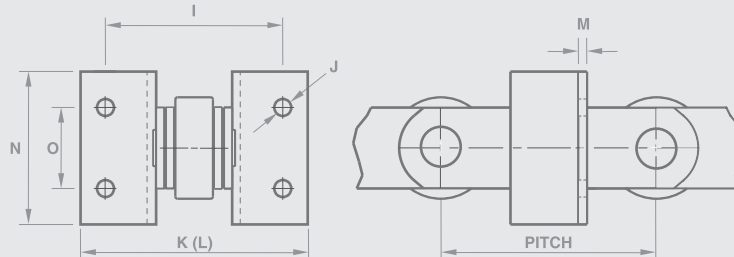

Chain	Technical Details		F2 Attachments							
	Breaking Load lbf	Minimum Pitch Inner Plate	Minimum Pitch Outer Plate	Transverse Pitch	Attachment Hole Size	Width Over Attachment Outer Plate	Width Over Attachment Inner Plate	Attachment Thickness	Attachment Face Height	Pitch of Attachment Holes
			I	J	K (Max)	L (Max)	M	N	O	
3000	50.8	38.1	44.5	7.4	72.0	68.0	3.0	44.5	25.4	0.068
6000 / 7500	69.9	57.2	76.2	9.2	116.0	106.0	4.0	56.0	31.8	0.104
12000 / 15000	101.6	82.6	88.9	10.5	133.0	122.0	5.0	84.0	57.2	0.231
24000 / 30000	139.7	114.3	108.0	12.2	159.0	146.0	6.0	108.0	69.9	0.580
36000 / 45000	165.1	133.4	146.0	13.7	200.0	202.0	8.0	152.0	88.9	1.270
60000	165.1	133.4	146.0	13.7	200.0	202.0	8.0	152.0	88.9	1.270
90000	190.5	152.4	171.5	19.7	252.0	229.0	10.0	152.0	88.9	1.810

Conveyor Chain

BS L Attachments (Integral)

Section 1

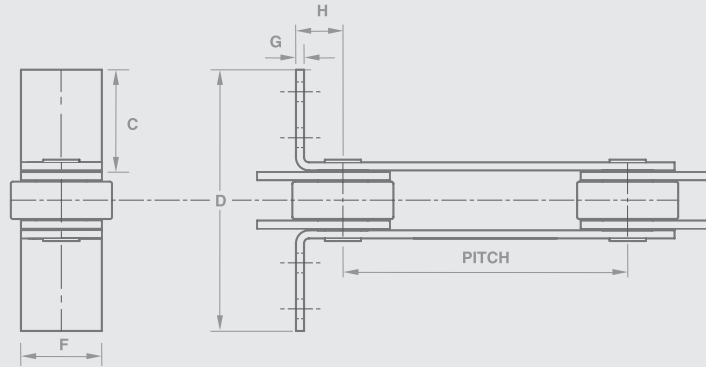

Chain Technical Details

Breaking Load lbf	Type	Transverse Pitch	Pitch of Attachment Holes	Attachment Face Length	Width Over Attachment Outer	Attachment Hole Diameter	Total Height of Attachment	Attachment Thickness	Distance of Pitch point to Attachment Face	Box Width*	Mass (kg)
		A	B	C	D	E	F	G	H		
3000	L0	-	-	28.7	74.2	-	18.0	1.8	16.0	76.2	0.007
	L0	-	-	41.4	99.6	-	18.0	1.8	16.0	101.6	0.010
	L0	-	-	54.1	125.0	-	18.0	1.8	16.0	127.0	0.013
	L0	-	-	66.8	150.4	-	18.0	1.8	16.0	152.4	0.016
	L1	41.4	-	25.4	67.6	7.4	18.0	1.8	16.0	-	0.007
	L2	41.4	19.0	41.4	100.0	7.4	18.0	1.8	16.0	-	0.009
6000 / 7500	L0	-	-	48.3	123.5	-	25.4	3.8	19.0	127.0	0.041
	L0	-	-	61.0	148.9	-	25.4	3.8	19.0	152.4	0.051
	L0	-	-	86.4	199.7	-	25.4	3.8	19.0	203.2	0.071
	L0	-	-	111.8	250.5	-	25.4	3.8	19.0	254.0	0.091
	L0	-	-	137.2	301.3	-	25.4	3.8	19.0	304.8	0.111
	L1	58.9	-	31.8	107.0	9.2	25.4	3.8	19.0	-	0.025
	L2	58.9	21.6	48.3	123.0	9.2	25.4	3.8	19.0	-	0.041
12000 / 15000	L0	-	-	44.5	122.0	-	38.1	3.8	25.4	127.0	0.058
	L0	-	-	57.2	147.4	-	38.1	3.8	25.4	152.4	0.072
	L0	-	-	82.6	198.2	-	38.1	3.8	25.4	203.2	0.101
	L0	-	-	108.0	249.0	-	38.1	3.8	25.4	254.0	0.130
	L0	-	-	133.4	299.8	-	38.1	3.8	25.4	304.8	0.160
	L1	73.4	-	36.8	106.8	10.5	38.1	3.8	25.4	-	0.045
	L2	73.4	24.0	57.2	148.6	10.5	38.1	3.8	25.4	-	0.073
24000 / 30000	L0	-	-	128.5	300.0	-	51.0	5.1	35.0	320.0	0.267
36000 / 45000	L0	-	-	135.2	330.0	-	61.0	7.6	42.0	350.0	0.479
60000	L0	-	-	135.2	330.0	-	61.0	7.6	42.0	350.0	0.479

* ALTERNATIVE WIDTH AVAILABLE. PLEASE ENQUIRE.

Conveyor Chain

BS Attachments Holes in Link Plates

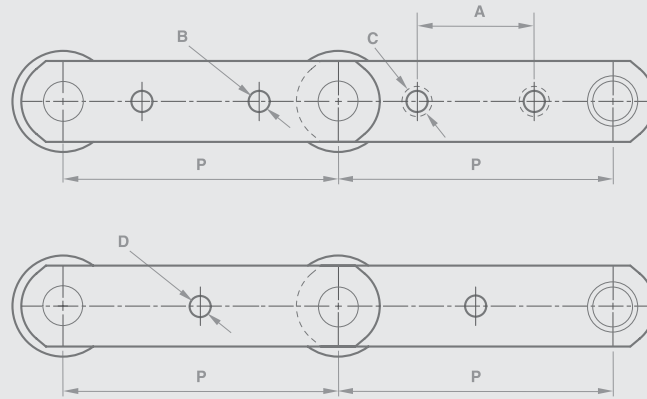

Chain	Technical Details One Hole				Technical Details Two Holes			
	Minimum Pitch Bush Chain	Minimum Pitch Small Roller	Minimum Pitch Large Roller	Hole Diameter	Minimum Pitch*	Attachment Hole Pitch	Hole Diameter	Cone Diameter
	P (min)	P (min)	P (min)	D	P (min)	A	B	C
3000	50.8	50.8	76.20	6.65	-	-	-	-
6000	-	95.3	-	9.9	95.3	38.1	8.3	14.7
7500	-	95.3	-	9.9	127.0	63.5	8.3	14.7
12000/15000	-	-	133.35	13.1	101.6	25.4	9.9	17.8
					108.0	34.9	9.9	17.8
					139.7	60.3	9.9	17.8
					177.8	101.6	9.9	17.8
24000/30000	-	-	190.50	19.4	127.0	34.9	9.9	17.8
					152.4	60.3	9.9	17.8
					171.5	82.6	9.9	17.8
					190.5	101.6	9.9	17.8
					228.6	139.7	9.9	17.8
36000/45000	241.3	241.3	317.50	22.6	152.4	44.5	11.5	20.8
					190.5	82.6	11.5	20.8
					228.6	114.3	11.5	20.8
					304.8	190.5	11.5	20.8
60000	241.3	241.3	317.50	22.6	152.4	44.5	11.5	20.8
					190.5	82.6	11.5	20.8
					222.3	114.3	11.5	20.8
					298.5	190.5	11.5	20.8
90000	279.4	279.4	330.20	29.0	177.8	50.8	16.7	30.5
					228.6	108.0	16.7	30.5
					304.8	184.2	16.7	30.5

* BASED ON SMALL PLAIN ROLLER - WILL BE INCREASED PRO RATA FOR OTHER TYPES.

Conveyor Chain

BS Extended Bearing Pins

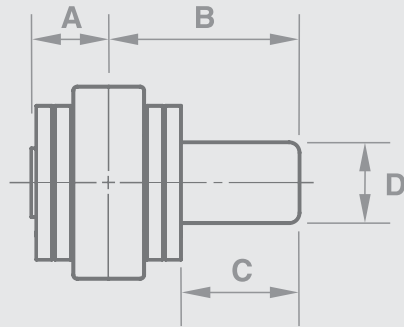

Chain Technical Details

Breaking Load lbf	Centre Distance To rivet End	Centre Distance To pin End	Extension Length	Extension Diameter	Mass (kg)
A	B	C	D		
3000	11.0	35.0	25.4	11.0	0.020
7500	19.0	55.0	38.0	16.0	0.059
15000	23.0	65.0	44.5	22.2	0.132
30000	30.0	84.0	57.2	28.6	0.286
45000	41.2	107.2	70.0	35.0	0.522
60000	40.0	107.2	70.0	35.0	0.522
90000	47.0	113.3	70.0	38.0	0.620

N.B EXTENDED BEARING PINS ARE AN INTEGRAL PART OF THE CHAIN ASSEMBLY AND CANNOT BE REMOVED WITHOUT DISMANTLING THE CHAIN .
 EXTENDED BEARING PINS CAN BE SPECIFIED AT ANY PITCH POINT OF THE CHAIN.
 EXTENSIONS ARE CASE - HARDENED OR CAN REMAIN SOFT TO SUIT CUSTOMERS REQUIREMENTS.

Conveyor Chain

BS Spigot Pins

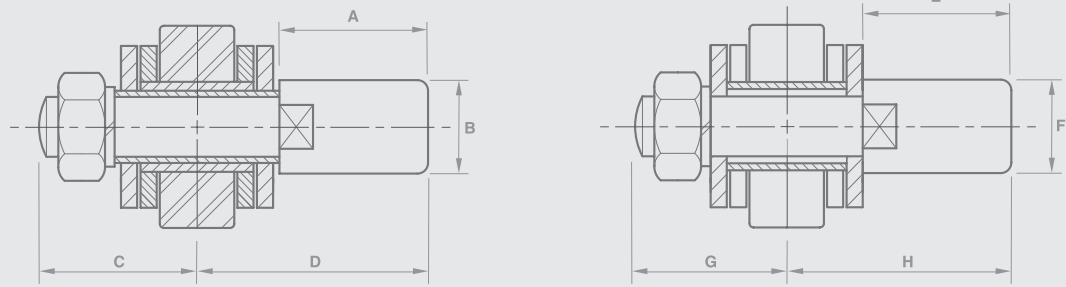

Chain Technical Details Spigot pins-Through hollow pin type 1

Breaking Load lbf	Extended Length	Extension Diameter	Centre Distance To nut End	Centre Distance To Pin End
	A	B	C	D
3000	-	-	-	-
6000	38.1	16.0	31.0	57.0
7500	-	-	-	-
12000	44.5	19.0	36.30	66.3
15000	-	-	-	-
24000	57.2	28.6	48.0	85.3
30000	-	-	-	-
36000	70.0	31.8	61.0	109.0
45000	-	-	-	-
60000	-	-	-	-
90000	-	-	-	-

Spigot pins-Mid pitch on outer link type 2

Extended Length	Extension Diameter	Centre Distance To nut End	Centre Distance To pin End	Mass (kg)
E	F	G	H	
25.4	11.0	17.0	35.0	0.036
38.1	16.0	29.2	56.0	0.112
38.1	16.0	29.2	56.0	0.112
44.5	19.0	34.3	64.8	0.200
44.5	19.0	34.3	64.8	0.200
57.2	28.6	45.7	83.8	0.560
57.2	28.6	45.7	83.8	0.560
70.0	31.8	58.5	107.0	0.900
70.0	31.8	58.5	107.0	0.900
70.0	31.8	58.5	107.0	0.900
70.0	38.0	71.0	113.0	1.490

Conveyor Chain

BS Outboard Rollers

Section 1

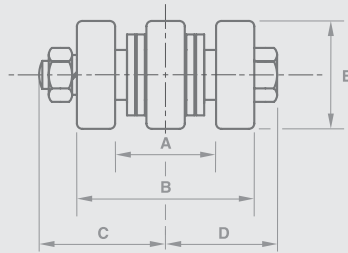

Chain Technical Details

Breaking Load lbf	Distance Between Outboard Rollers	Distance Over Outboard Rollers	Centre Distance To nut End	Centre Distance To bolt End	Roller Diameter	Mass (kg)	Roller Load Per Pitch Point (kg)
	A	B	C	D	E		
6000	44.45	75.0	55.6	46.5	33.3	0.26	165
12000	50.80	88.9	68.5	57.0	50.8	0.73	290
24000	66.00	118.0	86.6	75.7	69.9	1.94	545
36000	94.00	171.5	113.5	106.0	92.1	4.74	725

BALL BEARING OUTBOARD ROLLERS
BOLTED THROUGH HOLLOW BEARING PINS

Conveyor Chain

ISO 1977 Specification

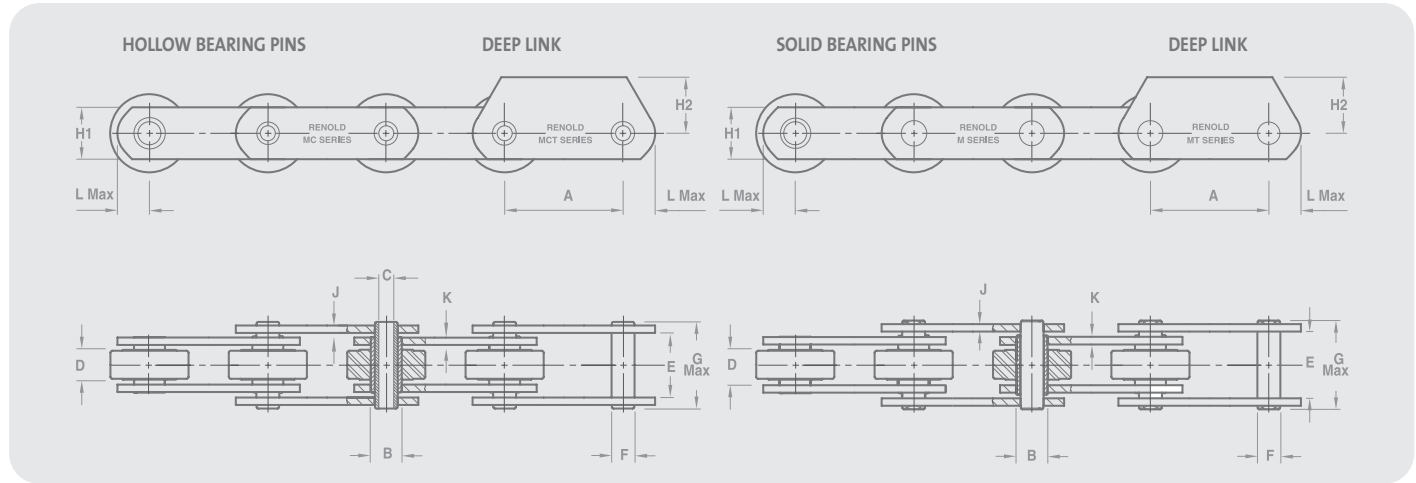

Hollow Bearing Pin

Chain Technical Details

Chain No	Breaking Load Min Newtons	PITCH Min	PITCH Max	BUSH Dia Max	Hollow Bearing Pin Bore Dia Min	INSIDE Width Inner Min	Width Outer Min	PIN Dia Max	PIN Len Max	Plate Height	Plate Height	Plate Width Outer	Plate Width Inner	Head Max
		A	A	B	C	D	E	F	G	H1	H2	J	K	L
MC56	56000	80	250	21.0	10.2	24.0	33.7	15.5	46.5	35.0	32.5	4.0	4.0	19.4
MC112	112000	100	315	29.0	14.3	32.0	45.7	22.0	63.0	50.0	45.0	6.0	6.0	27.3
MC224	224000	160	500	41.0	20.3	43.0	60.8	31.0	83.0	70.0	65.0	8.0	8.0	37.8

Solid Bearing Pin

Chain Technical Details

Chain No	Breaking Load Min Newtons	PITCH Min	PITCH Max	BUSH Dia Max	Hollow Bearing Pin Bore Dia Min	INSIDE Width Inner Min	Width Outer Min	PIN Dia Max	PIN Len Max	Plate Height	Plate Height	Plate Width Outer	Plate Width Inner	Head Max
		A	A	B	C	D	E	F	G	H1	H2	J	K	L
M40	40000	63	250	12.5	-	20.0	28.3	8.5	41.0	25.0	22.5	3.5	3.5	15.0
M56	56000	63	250	15.0	-	24.0	33.3	10.0	47.0	30.0	30.0	4.0	4.0	17.5
M80	80000	80	315	18.0	-	28.0	39.4	12.0	54.6	35.0	32.5	5.0	5.0	20.2
M112	112000	80	400	21.0	-	32.0	45.5	15.0	60.6	40.0	40.0	5.0	6.0	23.0
M160	160000	100	500	25.0	-	37.0	52.5	18.0	72.6	50.0	45.0	6.0	7.0	29.0
M224	224000	125	630	30.0	-	43.0	60.6	21.0	84.0	60.0	60.0	6.0	8.0	35.0
M315	315000	160	630	36.0	-	48.0	70.7	25.0	97.0	70.0	65.0	8.0	10.0	38.1
M450	450000	200	800	42.0	-	56.0	82.8	30.0	114.0	80.0	80.0	10.0	12.0	43.4
M630	630000	250	1000	50.0	-	66.0	97.0	36.0	133.0	100.0	90.0	14.0	14.0	54.1
M900	900000	250	1000	60.0	-	78.0	113.0	44.0	153.0	120.0	120.0	16.0	16.0	64.7

DIMENSIONS LISTED ABOVE WILL NOT VARY WITH PITCH SIZE IN EACH GIVEN BREAKING LOAD.
 STAINLESS AND ZINC PLATED CHAINS ARE AVAILABLE TO ORDER.
 FOR THE DETAILS OF INDIVIDUAL PITCH SIZES, ROLLERS, AND SPARE LINKS, SEE PAGES 24 - 29.
 FOR ATTACHMENTS SEE PAGES 30 - 34.

Conveyor Chain

ISO Standard – Bush

Pitch mm	Chain No (Bush)	kg/m
-------------	--------------------	------

M40 Solid Pin

63	M40B63	2.29
80	M40B80	2.11
100	M40B100	1.97
125	M40B125	1.86
160	M40B160	1.76
200	M40B200	1.70
250	M40B250	1.63

M56 Solid Pin

63	M56B63	3.50
80	M56B80	3.20
100	M56B100	2.90
125	M56B125	2.70
160	M56B160	2.50
200	M56B200	2.40
250	M56B250	2.30

MC56 Hollow Pin

80	MC56B80	3.67
100	MC56B100	3.38
125	MC56B125	3.15
160	MC56B160	2.95
200	MC56B200	2.81
250	MC56B250	2.69

M80 Solid Pin

80	M80B80	4.51
100	M80B100	4.13
125	M80B125	3.83
160	M80B160	3.57
200	M80B200	3.38
250	M80B250	3.32
315	M80B315	3.20

M112 Solid Pin

80	M112B80	6.30
100	M112B100	5.60
125	M112B125	5.80
160	M112B160	5.37
200	M112B200	4.63
250	M112B250	4.43
315	M112B315	4.10
400	M112B400	3.90

Pitch mm	Chain No (Bush)	kg/m
-------------	--------------------	------

MC112 Hollow Pin

100	MC112B100	7.60
125	MC112B125	6.96
160	MC112B160	6.40
200	MC112B200	6.00
250	MC112B250	5.68
315	MC112B315	5.42

M160 Solid Pin

100	M160B100	9.80
125	M160B125	8.50
160	M160B160	7.80
200	M160B200	7.30
250	M160B250	6.90
315	M160B315	6.57
400	M160B400	6.30
500	M160B500	6.08

M224 Solid Pin

125	M224B125	12.30
160	M224B160	11.10
200	M224B200	10.20
250	M224B250	9.60
315	M224B315	8.98
400	M224B400	8.50
500	M224B500	8.10
630	M224B630	7.80

MC224 Hollow Pin

160	MC224B160	12.45
200	MC224B200	10.77
250	MC224B250	9.94
315	MC224B315	9.30
400	MC224B400	8.62
500	MC224B500	8.15

M315 Solid Pin

160	M315B160	19.20
200	M315B200	16.70
250	M315B250	15.60
315	M315B315	14.70
400	M315B400	13.80
500	M315B500	13.20
630	M315B630	12.80

M450 Solid Pin

200	M450B200	23.90
250	M450B250	22.12
315	M450B315	20.65
400	M450B400	19.45
500	M450B500	18.56
630	M450B630	17.83
800	M450B800	17.22

M630 Solid Pin

250	M630B250	35.28
315	M630B315	32.53
400	M630B400	30.30
500	M630B500	28.64
630	M630B630	27.27
800	M630B800	26.15
1000	M630B1000	25.32

M900 Solid Pin

250	M900B250	53.20
315	M900B315	48.20
400	M900B400	44.50
500	M900B500	41.60
630	M900B630	39.20
800	M900B800	37.25
1000	M900B1000	35.80

* Add an F to the end of the part number if a product with flattened round parts (Pin and Bush) is required.

Conveyor Chain

ISO Standard – Small Roller

Pitch mm	Chain No (Small)	kg/m
-------------	---------------------	------

M40 Solid Pin

63	M40S63	2.59
80	M40S80	2.34
100	M40S100	2.15
125	M40S125	2.00
160	M40S160	1.87
200	M40S200	1.78
250	M40S250	1.70

M56 Solid Pin

63	M56S63	3.98
80	M56S80	3.50
100	M56S100	3.20
125	M56S125	2.90
160	M56S160	2.70
200	M56S200	2.50
250	M56S250	2.40

MC56 Hollow Pin

80	MC56S80	4.65
100	MC56S100	4.16
125	MC56S125	3.77
160	MC56S160	3.44
200	MC56S200	3.20
250	MC56S250	3.00

M80 Solid Pin

80	M80S80	5.45
100	M80S100	4.90
125	M80S125	4.46
160	M80S160	4.07
200	M80S200	3.80
250	M80S250	3.58
315	M80S315	3.40

M112 Solid Pin

80	M112S80	7.20
100	M112S100	6.00
125	M112S125	5.80
160	M112S160	5.37
200	M112S200	5.00
250	M112S250	4.75
315	M112S315	4.60
400	M112S400	4.45

* Add an F to the end of the part number if a product with flattened round parts (Pin and Bush) is required.

Pitch mm	Chain No (Small)	kg/m
-------------	---------------------	------

MC112 Hollow Pin

100	MC112S100	9.34
125	MC112S125	8.35
160	MC112S160	7.45
200	MC112S200	6.87
250	MC112S250	6.38
315	MC112S315	5.97

M160 Solid Pin

100	M160S100	11.20
125	M160S125	10.00
160	M160S160	9.00
200	M160S200	8.35
250	M160S250	7.78
315	M160S315	7.31
400	M160S400	6.92
500	M160S500	6.64

M224 Solid Pin

125	M224S125	14.05
160	M224S160	12.40
200	M224S200	11.28
250	M224S250	10.40
315	M224S315	9.60
400	M224S400	8.90
500	M224S500	8.50
630	M224S630	8.00

MC224 Hollow Pin

160	MC224S160	15.51
200	MC224S200	13.22
250	MC224S250	11.90
315	MC224S315	10.86
400	MC224S400	9.65
500	MC224S500	9.13

M315 Solid Pin

160	M315S160	21.16
200	M315S200	18.40
250	M315S250	16.90
315	M315S315	15.70
400	M315S400	14.70
500	M315S500	13.90
630	M315S630	13.30

M450 Solid Pin

200	M450S200	26.90
250	M450S250	24.52
315	M450S315	22.55
400	M450S400	20.95
500	M450S500	19.76
630	M450S630	18.78
800	M450S800	17.97

M630 Solid Pin

250	M630S250	38.80
315	M630S315	25.32
400	M630S400	32.50
500	M630S500	30.40
630	M630S630	28.66
800	M630S800	27.25
1000	M630S1000	26.20

M900 Solid Pin

250	M900S250	55.80
315	M900S315	50.48
400	M900S400	46.12
500	M900S500	42.90
630	M900S630	40.24
800	M900S800	38.00
1000	M900S1000	36.45

Conveyor Chain

ISO Standard – Flanged Roller

Pitch mm	Chain No (Flanged)	kg/m
-------------	-----------------------	------

M40 Solid Pin

63	M40F63	4.57
80	M40F80	3.90
100	M40F100	3.40
125	M40F125	3.00
160	M40F160	2.65
200	M40F200	2.40
250	M40F250	2.20

M56 Solid Pin

63	-	-
80	M56F80	6.20
100	M56F100	4.80
125	M56F125	4.22
160	M56F160	3.95
200	M56F200	3.60
250	M56F250	3.22

MC56 Hollow Pin

80	MC56F80	7.54
100	MC56F100	6.48
125	MC56F125	5.63
160	MC56F160	4.89
200	MC56F200	4.36
250	MC56F250	3.93

M80 Solid Pin

80	M80F80	9.88
100	M80F100	8.45
125	M80F125	7.30
160	M80F160	6.30
200	M80F200	5.57
250	M80F250	5.00
315	M80F315	4.52

M112 Solid Pin

80	-	-
100	M112F100	12.25
125	M112F125	10.58
160	M112F160	9.05
200	M112F200	7.95
250	M112F250	7.10
315	M112F315	6.40
400	M112F400	5.85

* Add an F to the end of the part number if a product with flattened round parts (Pin and Bush) is required.

Pitch mm	Chain No (Flanged)	kg/m
-------------	-----------------------	------

MC112 Hollow Pin

100	MC112F100	16.20
125	MC112F125	13.84
160	MC112F160	11.78
200	MC112F200	10.30
250	MC112F250	9.12
315	MC112F315	8.15

M160 Solid Pin

100	-	-
125	M160F125	16.50
160	M160F160	14.08
200	M160F200	12.30
250	M160F250	10.90
315	M160F315	9.74
400	M160F400	8.80
500	M160F500	8.10

M224 Solid Pin

125	-	-
160	M224F160	22.30
200	M224F200	19.10
250	M224F250	16.65
315	M224F315	14.70
400	M224F400	13.00
500	M224F500	11.70
630	M224F630	11.10

MC224 Hollow Pin

160	MC224F160	22.87
200	MC224F200	19.84
250	MC224F250	17.18
315	MC224F315	14.85
400	MC224F400	13.10
500	MC224F500	11.70

M315 Solid Pin

160	-	-
200	M315F200	31.00
250	M315F250	27.00
315	M315F315	23.60
400	M315F400	21.00
500	M315F500	19.00
630	M315F630	17.20

M450 Solid Pin

200	M450F200	47.56
250	M450F250	41.05
315	M450F315	35.67
400	M450F400	31.28
500	M450F500	28.02
630	M450F630	25.34
800	M450F800	25.13

M630 Solid Pin

250	M630F250	71.28
315	M630F315	61.10
400	M630F400	52.75
500	M630F500	46.64
630	M630F630	41.55
800	M630F800	37.40
1000	M630F1000	34.32

M900 Solid Pin

250	-	-
315	M900F315	88.41
400	M900F400	76.00
500	M900F500	66.80
630	M900F630	59.20
800	M900F800	53.00
1000	M900F1000	48.40

Conveyor Chain

ISO Standard – Plain Roller

Pitch mm	Chain No (Plain)	kg/m
-------------	---------------------	------

M40 Solid Pin

63	M40P63	4.33
80	M40P80	3.70
100	M40P100	3.25
125	M40P125	2.88
160	M40P160	2.56
200	M40P200	2.32
250	M40P250	2.14

M56 Solid Pin

80	M56P80	5.53
100	M56P100	4.80
125	M56P125	4.22
160	M56P160	3.70
200	M56P200	3.35
250	M56P250	3.06

MC56 Hollow Pin

80	MC56P80	6.68
100	MC56P100	5.78
125	MC56P125	-
160	MC56P160	4.43
200	MC56P200	3.98
250	MC56P250	3.62

M80 Solid Pin

80	M80P80	9.26
100	M80P100	7.95
125	M80P125	6.90
160	M80P160	5.98
200	M80P200	5.32
250	M80P250	4.80
315	M80P315	4.36

M112 Solid Pin

100	M112P100	11.30
125	M112P125	9.80
160	M112P160	8.48
200	M112P200	7.55
250	M112P250	6.80
315	M112P315	6.18
400	M112P400	5.67

* Add an F to the end of the part number if a product with flattened round parts (Pin and Bush) is required.

Pitch mm	Chain No (Plain)	kg/m
-------------	---------------------	------

MC112 Hollow Pin

100	MC112P100	14.90
125	MC112P125	12.80
160	MC112P160	10.96
200	MC112P200	9.65
250	MC112P250	8.60
315	MC112P315	7.73

M160 Solid Pin

125	M160P125	15.46
160	M160P160	13.24
200	M160P200	11.65
250	M160P250	10.38
315	M160P315	9.33
400	M160P400	8.48
500	M160P500	7.83

M224 Solid Pin

160	M224P160	20.00
200	M224P200	17.50
250	M224P250	15.50
315	M224P315	13.84
400	M224P400	12.50
500	M224P500	11.50
630	M224P630	10.67

MC224 Hollow Pin

160	MC224P160	21.75
200	MC224P200	18.65
250	MC224P250	16.17
315	MC224P315	14.12
400	MC224P400	12.45
500	MC224P500	11.21

M315 Solid Pin

200	M315P200	29.00
250	M315P250	25.40
315	M315P315	22.43
400	M315P400	20.00
500	M315P500	18.20
630	M315P630	16.70

M450 Solid Pin

200	M450P200	44.50
250	M450P250	38.60
315	M450P315	33.73
400	M450P400	29.75
500	M450P500	26.80
630	M450P630	24.37
800	M450P800	22.37

M630 Solid Pin

250	M630P250	60.40
315	M630P315	52.47
400	M630P400	46.00
500	M630P500	41.20
630	M630P630	37.24
800	M630P800	34.00
1000	M630P1000	31.60

M900 Solid Pin

315	M900P315	83.33
400	M900P400	72.00
500	M900P500	63.60
630	M900P630	56.67
800	M900P800	51.00
1000	M900P1000	46.80

Conveyor Chain

ISO Rollers

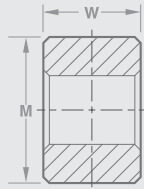

SMALL ROLLER

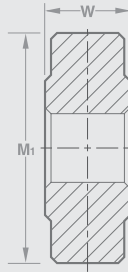

PLAIN ROLLER

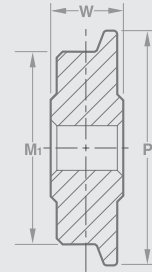

FLANGED ROLLER

Hollow Bearing Pin Rollers

Chain Technical Details

Chain No	Breaking Load Newtons	SMALL Tread Dia	Roller Width	PLAIN Tread Dia	Roller Width	FLANGED Tread Dia	Flange Dia	Roller Width
		M	W	M1	W	M1	P	W
MC56	56000	30.0	23.0	50.0	23.0	50.0	60.0	23.0
MC112	112000	42.0	31.0	70.0	31.0	70.0	85.0	31.0
MC224	224000	60.0	42.0	100.0	42.0	100.0	120.0	42.0

Solid Bearing Pin Rollers

Chain Technical Details

Chain No	Breaking Load Newtons	SMALL Tread Dia	Roller Width	PLAIN Tread Dia	Roller Width	FLANGED Tread Dia	Flange Dia	Roller Width
		M	W	M1	W	M1	P	W
M40	40000	18.0	19.0	36.0	19.0	36.0	42.0	19.0
M56	56000	21.0	23.0	42.0	23.0	42.0	50.0	23.0
M80	80000	25.0	27.0	50.0	27.0	50.0	60.0	27.0
M112	112000	30.0	31.0	60.0	31.0	60.0	70.0	31.0
M160	160000	36.0	36.0	70.0	36.0	70.0	85.0	36.0
M224	224000	42.0	42.0	85.0	42.0	85.0	100.0	42.0
M315	315000	50.0	47.0	100.0	47.0	100.0	120.0	47.0
M450	450000	60.0	55.0	120.0	55.0	120.0	140.0	55.0
M630	630000	70.0	65.0	140.0	65.0	140.0	170.0	65.0
M900	900000	85.0	76.0	170.0	76.0	170.0	210.0	76.0

ROLLER SELECTION DETAILS - SEE PAGE 76.

Conveyor Chain

ISO Connecting Links

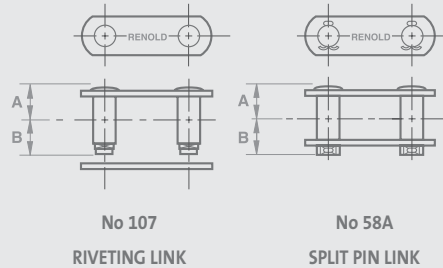

Hollow Bearing Pin Chain - Connecting Links

Chain

Technical Details

Chain No	Breaking Load Newtons	No 107 Chain Plain Side	Centre to Fastener Side	No 58A# Chain Chain Side	Centre to Fastener Side
		A	B	A	B
MC56	56000	22.9	22.9	22.9	29.1
MC112	112000	31.2	31.2	31.2	38.7
MC224	224000	41.2	41.2	41.2	50.9

Solid Bearing Pin Chain - Connecting Links

Chain

Technical Details

Chain No	Breaking Load Newtons	No 107 Chain Plain Side	Centre to Fastener Side	No 58A# Chain Chain Side	Centre to Fastener Side
		A	B	A	B
M40	40000	20.2	20.2	20.2	24.2
M56	56000	23.1	23.1	23.1	29.2
M80	80000	27.3	27.3	27.3	33.4
M112	112000	31.4	31.4	31.4	38.9
M160	160000	36.6	36.6	36.6	44.6
M224	224000	41.7	41.7	41.7	51.4
M315	315000	48.4	48.4	48.4	58.6
M450	450000	56.6	56.6	56.6	70.0
M630	630000	65.9	65.9	65.9	79.1
M900	900000	76.1	76.1	76.1	93.5

Conveyor Chain - Solid Pin Type

ISO K Attachments

Section 1

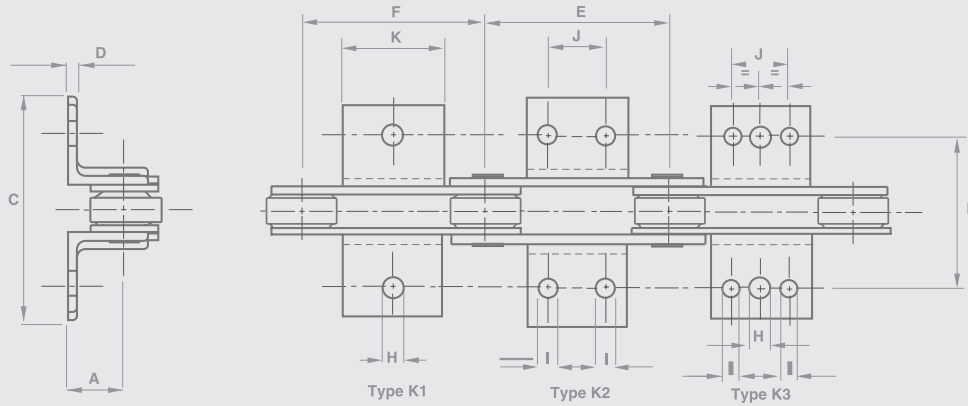

Solid Bearing Pin

Chain Technical Details

Chain No	Breaking Load Newtons	Platform Height	Transverse Pitch	Width Over Attachment Inner/Outer	Attachment Thickness Inner/Outer	Attachment Type	Attachment Minimum Outer Pitch	Attachment Minimum Inner Pitch	Centre Hole Dia	Outer Holes Dia	Hole Pitch	Platform Length	Mass (kg/Att)
		A	B	C (max)	D		E	F	H	I	J	K	
M40	40000	25	70	101 / 110	3.5	K1	63	63	9.0	-	-	20	0.04
						K2	80	80	-	9.0	20	40	0.07
						K3	100	100	9.0	9.0	40	60	0.11
						K3	125	125	9.0	9.0	65	85	0.15
M56	56000	30	88	116 / 126	5.0	K1	63	63	11.0	-	-	25	0.04
						K2	100	100	-	11.0	25	50	0.07
						K3	125	125	11.0	11.0	50	75	0.11
						K3	160	160	11.0	11.0	85	110	0.15
M80	80000	35	96	132 / 135	5.0	K1	80	80	11.0	-	-	25	0.10
						K3	125	125	11.0	11.0	50	75	0.25
						K3	160	160	11.0	11.0	85	110	0.37
						K3	200	200	11.0	11.0	125	150	0.50
M112	112000	40	110	150 / 164	6.0	K1	80	80	14.0	-	-	30	0.20
						K2	125	125	-	14.0	35	65	0.35
						K3	160	160	14.0	14.0	65	95	0.50
						K3	200	200	14.0	14.0	100	130	0.75
M160	160000	45	124	178 / 193	6.0	K1	100	100	14.0	-	-	30	0.20
						K2	160	160	-	14.0	50	80	0.45
						K3	200	200	14.0	14.0	85	115	0.65
						K3	250	250	14.0	14.0	145	175	0.95
M224	224000	55	140	206 / 224	8.0	K1	125	125	18.0	-	-	40	0.30
						K2	200	200	-	18.0	65	105	0.80
						K3	250	250	18.0	18.0	125	165	1.20
						K3	315	315	18.0	18.0	190	230	1.65
M315	315000	65	160	216 / 240	10.0	K1	160	160	18.0	-	-	35	0.50
						K2	200	200	-	18.0	50	85	0.85
						K2	250	250	-	18.0	100	135	1.40
						K2	315	315	-	18.0	155	190	1.85
M450	450000	75	180	228 / 255	10.0	K1	200	200	18.0	-	-	40	0.60
						K2	250	250	-	18.0	85	125	1.40
						K2	315	315	-	18.0	155	195	2.40
						K2	400	400	-	18.0	240	280	3.50
M630	630000	90	230	302 / 333	12.0	K1	250	250	24.0	-	-	50	1.30
						K2	315	315	-	24.0	100	150	3.70
						K2	400	400	-	24.0	190	240	5.60
						K2	500	500	-	24.0	300	350	7.50
M900	900000	110	280	358 / 393	15.0	K1	250	250	30.0	-	-	60	1.70
						K2	315	315	-	30.0	65	125	4.80
						K2	400	400	-	30.0	155	215	7.50
						K2	500	500	-	30.0	240	300	9.80

Conveyor Chain - Hollow Pin Type

ISO K Attachments (Welded)

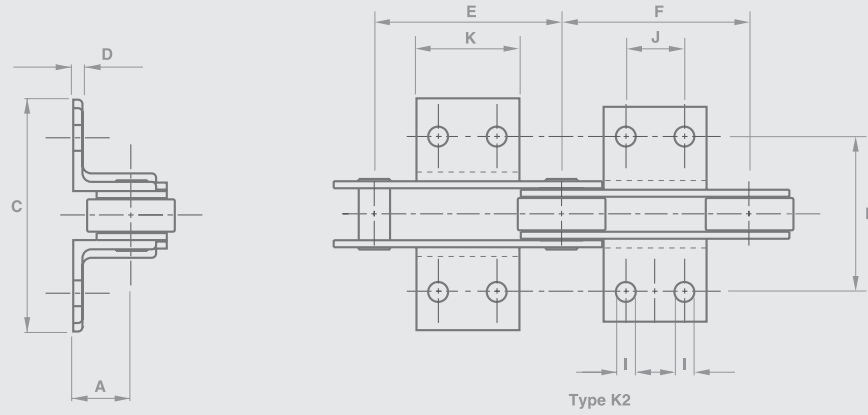

Hollow Bearing Pin

Chain

Technical Details

Chain No	Breaking Load Newtons	Platform Height	Transverse Pitch	Width Over Attachment Inner/Outer	Attachment Thickness Inner/Outer	Attachment Type	Attachment Minimum Outer Pitch	Attachment Minimum Inner Pitch	Outer Holes Dia	Hole Pitch	Platform Length	Mass (kg/Att)
		A	B	C (max)	D		E	F	I	J	K	
MC56	56000	35	88	126 / 137	5.0	K2	125	125	11	50	75	0.25
						K2	160	160	11	85	110	0.36
						K2	200	200	11	125	150	0.50
MC112	112000	45	110	171 / 186	6.0	K2	160	160	14	50	80	0.45
						K2	200	200	14	85	115	0.60
						K2	250	250	14	145	175	0.90
MC224	224000	65	140	206 / 220	8.0	K2	200	200	18	50	85	0.85
						K2	250	250	18	100	135	1.35
						K2	315	315	18	155	190	1.90

Conveyor Chain

ISO F Attachments (Welded)

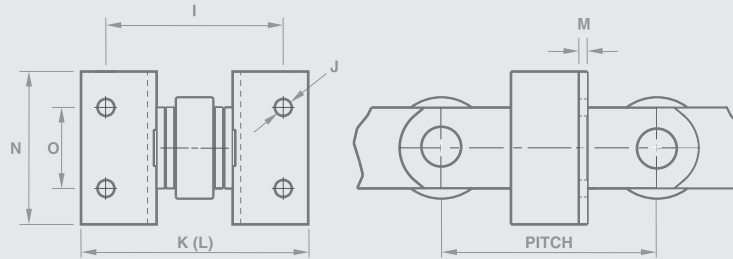

Chain Technical Details

Chain No	Breaking Load Newtons	Minimum Pitch Inner Plate	Minimum Pitch Outer Plate	Transverse Pitch	Attachment Hole Size	Width Over Att Outer Plate	Width Over Att Inner Plate	Attachment Thickness	Attachment Face Height	Pitch of Attachment	Mass (kg) Holes
				I	J	K	L	M	N	O	
M40	40000	80.0	80.0	70.0	9.0	110.0	101.0	3.5	40.0	20.0	0.085
M56	56000	100.0	100.0	88.0	11.0	126.0	116.0	5.0	50.0	25.0	0.204
MC56	56000	100.0	100.0	88.0	11.0	137.0	126.0	5.0	75.0	50.0	0.283
M80	80000	100.0	100.0	96.0	11.0	135.0	132.0	5.0	75.0	50.0	0.283
M112	112000	125.0	125.0	110.0	14.0	164.0	150.0	6.0	65.0	35.0	0.324
MC112	112000	125.0	125.0	110.0	14.0	186.0	171.0	6.0	80.0	50.0	0.629
M160	160000	125.0	125.0	124.0	14.0	193.0	178.0	6.0	80.0	50.0	8.629
M224	224000	160.0	160.0	140.0	18.0	224.0	206.0	8.0	105.0	65.0	1.078
MC224	244000	200.0	200.0	140.0	18.0	220.0	206.0	8.0	85.0	50.0	0.873
M315	315000	200.0	200.0	160.0	18.0	240.0	216.0	10.0	85.0	50.0	0.873
M450	450000	200.0	200.0	180.0	18.0	255.0	228.0	10.0	125.0	85.0	1.283
M630	630000	250.0	250.0	230.0	24.0	333.0	302.0	12.0	150.0	100.0	2.906
M900	900000	315.0	315.0	280.0	30.0	393.0	358.0	15.0	125.0	65.0	3.617

Conveyor Chain

ISO L Attachments (Integral)

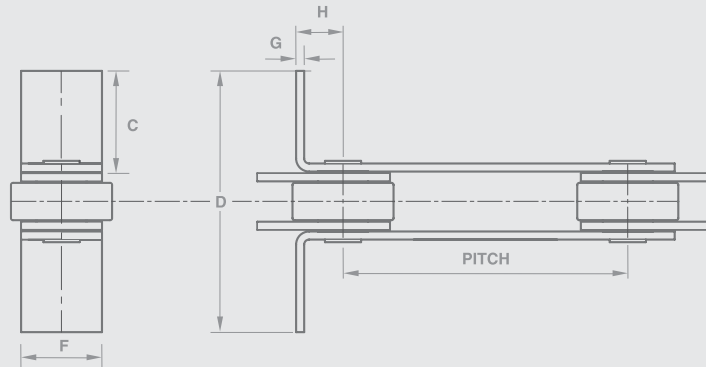

Chain

Technical Details

Chain No	Breaking Load Newtons	Type	Attachment Face Length	Width Over Attachment Outer	Total Height of Attachment	Attachment Thickness	Distance of Pitch point to Attachment Face	Box Width*	Mass (kg)
	lbf		C	D	F	G	H		
M40	40000	L0	75.85	180.0	25.0	3.5	30.0	200.0	0.054
M56	56000	L0	98.35	230.0	30.0	4.0	30.0	250.0	0.089
M80	80000	L0	95.30	230.0	35.0	5.0	30.0	250.0	0.124
M112	11200	L0	104.75	255.0	40.0	6.0	30.0	275.0	0.157
M160	160000	L0	113.75	280.0	50.0	7.0	35.0	300.0	0.254
M224	224000	L0	134.70	330.0	60.0	8.0	40.0	350.0	0.364
M315	315000	L0	154.65	380.0	70.0	10.0	50.0	400.0	0.645
M450	450000	L0	173.60	430.0	80.0	12.0	60.0	450.0	1.027
M630	630000	L0	166.50	430.0	100.0	14.0	70.0	450.0	1.676

* ALTERNATIVE WIDTH AVAILABLE. PLEASE ENQUIRE.

Conveyor Chain - Holes in Link Plates

ISO Attachments

Section 1

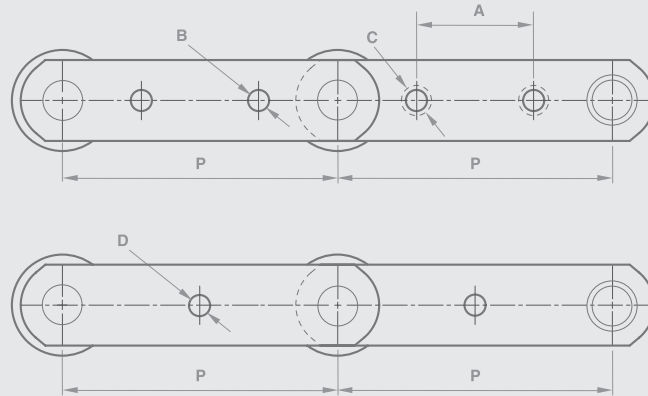

Chain No	Technical Details	One Hole	
Chain No	Breaking Load Newtons	Minimum Pitch Bush Chain	Hole Diameter Pitch
		P (min)	D
M40	40000	100.0	11.0
M56	56000	100.0	11.0
MC56	56000	100.0	11.0
M80	80000	100.0	15.0
M112	112000	125.0	15.0
MC112	112000	125.0	15.0
M160	160000	160.0	21.0
M224	224000	160.0	21.0
MC224	224000	160.0	21.0
M315	315000	200.0	25.0
M450	450000	200.0	30.0
M630	630000	250.0	36.0
M900	900000	315.0	45.0

Technical Details	Two Holes	
Minimum Pitch*	Attachment Hole	Hole Diameter
P (min)	A	B
160.0	63.0	9.0
160.0	63.0	11.0
160.0	80.0	11.0
200.0	80.0	11.0
200.0	80.0	14.0
200.0	100.0	14.0
250.0	100.0	14.0
250.0	100.0	18.0
315.0	125.0	18.0
315.0	125.0	18.0
315.0	125.0	18.0
400.0	160.0	24.0
500.0	200.0	30.0

* BASED ON SMALL PLAIN ROLLER - WILL BE INCREASED PRO RATA FOR OTHER TYPES.

Elevator Chain

Renold has been used successfully in elevator applications for many years and it has been found by experience that for most applications, chains that have been derived from the standard range of products are more than adequate. The inclusion of fillet welded K attachments to provide extra attachment strength and smaller than standard gearing rollers to reduce weight, are all that is required to produce a hard wearing and long lasting chain.

Where chains are to be used in abrasive and/or corrosive conditions then special heavy duty chains can be produced, a few examples of which are shown on the following pages.

Chain is fitted with fillet welded K attachments for the dynamic discharge (centrifugal) elevator and G attachments for positive discharge elevator. The details of the design of each of these types of elevator can be found in the Designer Guide section. It is sometimes necessary to modify the design, materials, or heat treatment of chain when certain aggressive materials are handled, and in these cases we suggest Renold Applications Engineers are consulted before a chain is specified.

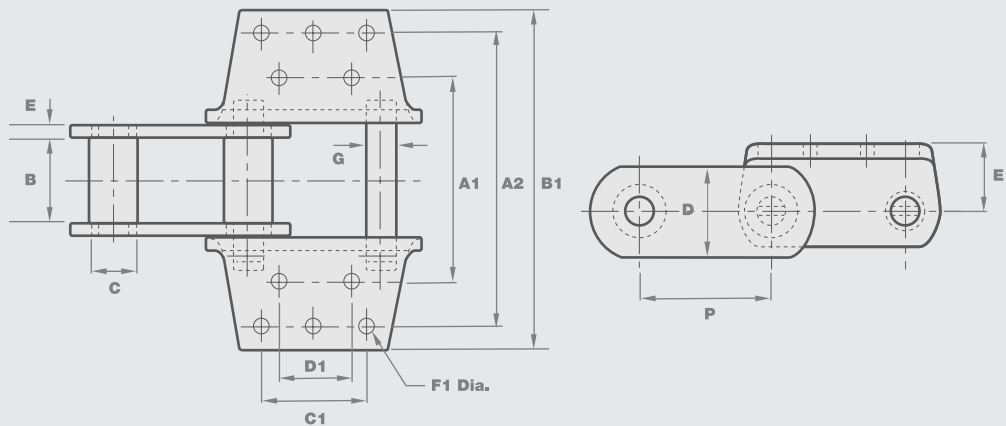

Bucket Elevator Chain

Chain

Technical Details

Chain No	Pitch	Inside Width	Plate		Roller Diam	Pin Diam								Type of Attachment No. of holes	Ultimate Strength
			Thickness	Height											
	P	B	E	D	C	G	A1	A2	B1	C1	D1	E1	F1		Newtons
6956-PB	6.0	76.200	12.700	76.200	44.450	25.400	-	184.150	242.888	-	-	47.625	17.463	K-24-4 holes	71174
6867-R	6.0	76.200	12.700	82.550	44.450	25.400	177.800	304.801	355.601	88.900	88.900	63.500	14.288	K-44-8 holes	62278
6866-R	6.0	63.500	12.700	76.200	60.325	31.750	-	160.338	249.238	-	-	60.325	17.475	K-2-4 holes	77402
6869-R	6.0	94.456	15.875	101.600	60.325	31.750	228.600	330.201	381.001	114.300	69.850	76.200	17.475	K-44-8 holes	97865
6969-R	6.0	94.463	15.875	101.600	63.500	38.100	228.600	330.201	381.001	114.300	69.850	76.200	17.475	K-44-8 holes	133452
6864-R	7.0	94.463	15.875	101.600	60.325	31.750	228.600	330.201	381.001	139.700	95.250	76.200	17.475	K-443-10 holes	97865
6874	7.0	101.600	15.875	114.300	69.850	44.450	241.300	342.901	393.701	139.700	95.250	79.375	17.475	K-443/K-44-10 holes	169039
6875-R	7.0	95.250	15.875	101.600	63.500	38.100	228.600	330.201	381.001	139.700	95.250	76.200	17.475	K-443/K-44-10 holes	133452

Elevator Chain

BS 4116 Part 4

Section 1

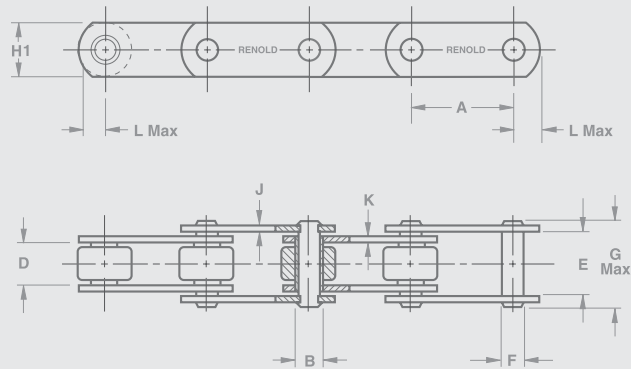

BS Elevator Chain- Solid Bearing Pin

Chain Technical Details

Breaking Load (min) lbf	Newtons	B.S. Series Ref	Pitch Min Inch	Max Inch	Min mm	Max mm	Bush Dia Max	Inside Width Inner Min	Width Outer Min	Pin Dia Max	Len Max	Plate Height	Width Outer	Width Inner	Head Max
			A	A	A	A	B	D	E	F	G	H1	J	K	L
7500	33000	35033	1.5	6.0	38.1	152.4	18.0	15.0	25.4	14.0	38.0	25.4	3.8	3.8	15.0
15000	67000	45067	2.0	9.0	50.8	228.6	23.6	19.0	32.5	19.0	46.0	38.1	3.8	5.1	22.1
30000	134000	55134	3.5	12.0	88.9	304.8	33.2	25.4	43.0	26.9	60.0	51.0	5.1	7.1	29.7
45000	200000	65200	5.0	18.0	127.0	457.2	38.1	38.1	59.0	31.8	82.0	61.0	7.6	8.9	34.8
60000	267000	75267	6.0	18.0	152.4	457.2	38.1	38.1	59.0	23.0	80.0	61.0	7.6	8.9	34.8
90000	400000	85400	6.0	24.0	152.4	609.6	38.1	38.1	66.3	29.4	94.0	63.5	10.0	13.0	35.8

THE DIMENSIONS LISTED WILL NOT VARY WITH PITCH SIZE FOR EACH GIVEN BREAKING LOAD.
 Stainless steel and zinc plated chains are available to order. For mass of chains see page 9.

Elevator Chain

BS K Attachments

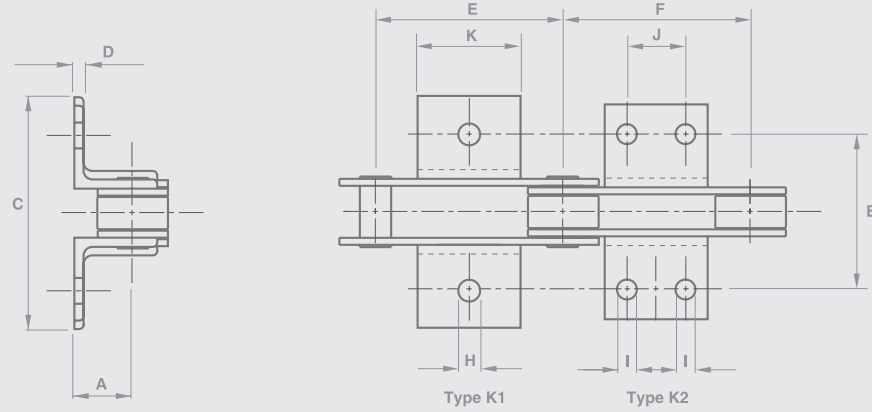

BS K Attachments (Welded)

Chain Technical Details

Breaking Load lbf	Newtons	Platform Height	Transverse Pitch	Width Over Attachment Inner/Outer	Attachment Thickness Inner/Outer	Attachment Type	Attachment Minimum Outer Pitch	Attachment Minimum Inner Pitch	Centre Hole Dia	Outer Holes Dia	Attachment Hole Pitch	Platform Length	Mass (kg/Att)
		A	B	C	D		E	F	H	I	J	K	
7500	33000	19.0	76.2	102/118	4	K1	63.5	76.2	10.5	-	-	28	0.054
						K1	88.9	101.6	10.6	-	-	56	0.104
						K2	88.9	101.6	-	9.2	31.8	56	0.104
						K2	114.3	127.0	-	9.2	57.2	84	0.163
15000	67000	31.8	88.9	125/136	5	K1	88.9	101.6	13.7	-	-	56	0.193
						K2	88.9	101.6	-	10.5	31.8	56	0.193
						K2	114.3	152.4	-	10.5	57.2	84	0.289
						K2	152.4	177.8	-	10.5	88.9	127	0.443
30000	134000	38.0	108.0	145/159	6	K2	127.0	127.0	-	12.2	31.8	56	0.299
						K2	152.4	152.4	-	12.2	57.2	84	0.449
						K2	177.8	177.8	-	12.2	69.9	108	0.581
						K2	203.2	203.2	-	12.2	88.9	127	0.685
K2	228.6	228.6	-	12.2	133.4	168	0.907						
45000	200000	51.0	146.0	182/200	8	K2	152.4	152.4	-	13.7	38.1	70	0.581
						K2	203.2	203.2	-	13.7	76.2	112	0.930
						K2	228.6	228.6	-	13.7	88.9	152	1.220
						K2	304.8	304.8	-	13.7	165.1	229	1.905
60000	267000	51.0	146.0	182/200	8	K2	152.4	152.4	-	13.7	38.1	70	0.581
						K2	203.2	203.2	-	13.7	76.2	112	0.930
						K2	228.6	228.6	-	13.7	88.9	152	1.220
						K2	304.8	304.8	-	13.7	165.1	229	1.905
90000	400000	57.0	171.5	229/252	10	K1	228.6	228.6	19.5	-	-	89	1.050
						K2	228.6	228.6	-	19.5	44.5	89	1.050
						K2	228.6	228.6	-	19.5	88.9	152	1.810
						K2	304.8	304.8	-	19.5	165.1	229	2.710

Elevator Chain

G2 Attachments

Produced to order; modifications to design and dimensions can be made to suit customer's own requirements.

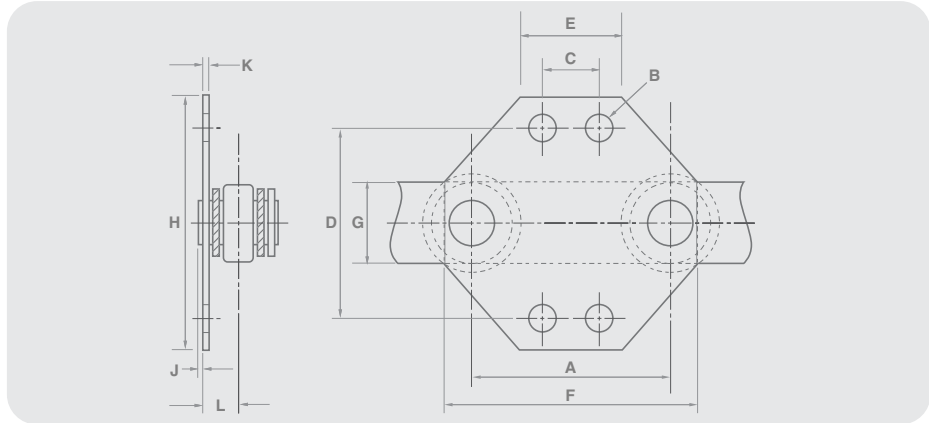

BS G2 Attachments (Internal)

Chain Breaking Load lbf.	N	Chain Pitch A	* Hole Dia. B	Horizontal Centres C	Vertical Centres D	Flat at top of Attachment E	Overall Width F	Chain Plate Depth G	Overall Depth H	Pin Projection J	Plate Thickness Line K	Face to Chain Centre L	Mass Each kg
7,500	33,000	76.2	9.35	22.23	57.15	44.45	105.41	25.40	82.55	1.91	3.80	16.76	0.12
		101.6	9.35	38.10	57.15	69.85	130.81	25.40	82.55	1.91	3.80	16.76	0.16
		152.4	9.35	38.10	57.15	69.85	181.61	25.40	82.55	1.91	3.80	16.76	0.20
15,000	67,000	101.6	10.69	31.75	76.20	57.15	143.51	38.10	101.6	2.29	3.80	20.32	0.19
		152.4	10.69	63.50	76.20	107.95	194.31	38.10	101.6	2.29	3.80	20.32	0.29
30,000	134,000	152.4	12.30	50.80	101.6	88.9	208.28	50.80	139.7	3.05	5.08	26.67	0.50
		203.2	12.30	76.20	114.3	114.3	259.10	50.80	152.4	3.05	5.08	26.67	0.80
45,000	200,000	203.2	13.87	88.90	127.0	127.0	269.20	60.96	165.1	3.30	7.60	37.34	1.23
		304.8	13.87	88.90	127.0	127.0	370.80	60.96	165.1	3.30	7.60	37.34	1.55

* Alternatively, square holes can be provided

Wheels to have shroud removed on one side.

Produced to order; modifications to design and dimensions can be made to suit customer's own requirements.

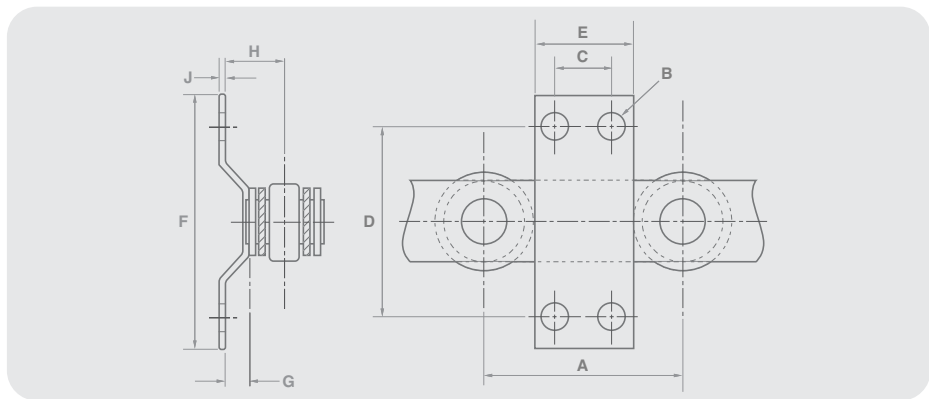

BS G2 Attachments (Welded)

Chain Breaking Load lbf.	N	Chain Pitch A	Hole Dia. B	Horizontal Centres C	Vertical Centres D	Attachment Width E	Attachment Depth F	Projection from chain plate G	Projection from chain centre H	Attachment Thickness J	Mass each kg
7,500	33,000	76.2	9.35	22.23	57.15	44.45	82.55	14.99	31.75	3.80	0.12
		101.6	9.35	38.10	57.15	69.85	82.55	14.99	31.75	3.80	0.19
		152.4	9.35	38.10	57.15	69.85	82.55	14.99	31.75	3.80	0.19
15,000	67,000	101.6	10.69	31.75	76.2	57.15	101.60	17.78	38.10	4.75	0.24
		152.4	10.69	63.50	76.2	107.95	101.60	17.78	38.10	4.75	0.45
30,000	134,000	152.4	12.30	50.80	101.6	88.9	139.70	24.13	50.80	6.35	0.67
		203.2	12.30	76.20	114.3	114.3	152.40	24.13	50.80	6.35	0.94
45,000	200,000	203.2	13.87	88.90	127.0	127.0	165.10	26.16	63.50	7.92	1.41
		304.8	13.87	88.90	127.0	127.0	165.10	26.16	63.50	7.92	1.41

Elevator Chain

ISO - 1977, DIN8167, BS4116

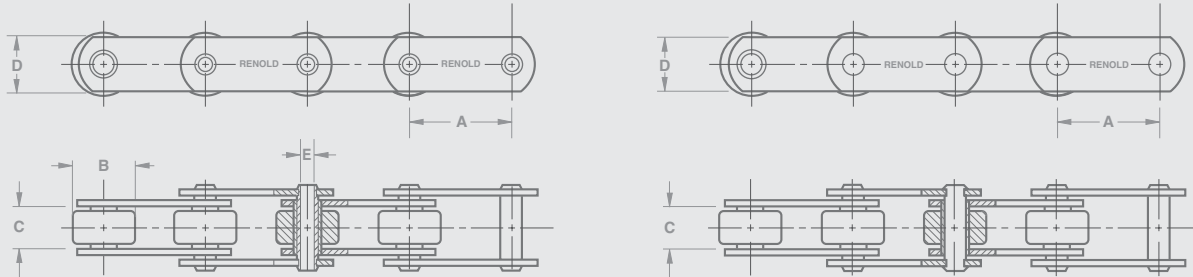

ISO Elevator Chain - Solid Bearing Pin

Chain Technical Details

Chain No	Breaking Load Min Newtons	Pitch Min	Max	Roller Dia Max	Inside Width Inner Min	Width Outer Min	Pin Dia Max	Len Max	Plate Height	Width Outer	Width Inner	Head Max
		A	A	B	D	E	F	G	H1	J	K	L
M40	40000	63	250	12.5	20.0	28.3	6.5	41.0	25.0	3.5	3.5	15.0
M56	56000	63	250	15.0	24.0	33.3	10.0	46.5	30.0	4.0	4.0	17.5
M80	80000	80	315	18.0	28.0	39.4	12.0	55.0	35.0	5.0	5.0	20.2
M112	112000	80	400	21.0	32.0	45.5	15.0	63.5	40.0	6.0	6.0	23.0
M160	160000	100	500	25.0	37.0	52.5	18.0	73.5	50.0	7.0	7.0	29.0
M224	224000	125	630	30.0	43.0	60.6	21.0	84.0	60.0	8.0	8.0	35.0
M315	315000	160	630	36.0	48.0	70.7	25.0	97.0	70.0	10.0	10.0	38.1
M450	450000	200	800	42.0	56.0	82.8	30.0	114.0	80.0	12.0	12.0	43.4
M630	630000	250	1000	50.0	66.0	97.0	36.0	133.0	100.0	14.0	14.0	54.1
M900	900000	250	1000	60.0	78.0	113.0	44.0	153.0	120.0	16.0	16.0	64.7

DIMENSIONS LISTED ABOVE WILL NOT VARY WITH PITCH SIZE IN EACH GIVEN BREAKING LOAD.

STAINLESS AND ZINC PLATED CHAINS ARE AVAILABLE TO ORDER.

For mass of chains see page 24.

Elevator Chain

ISO K Attachments

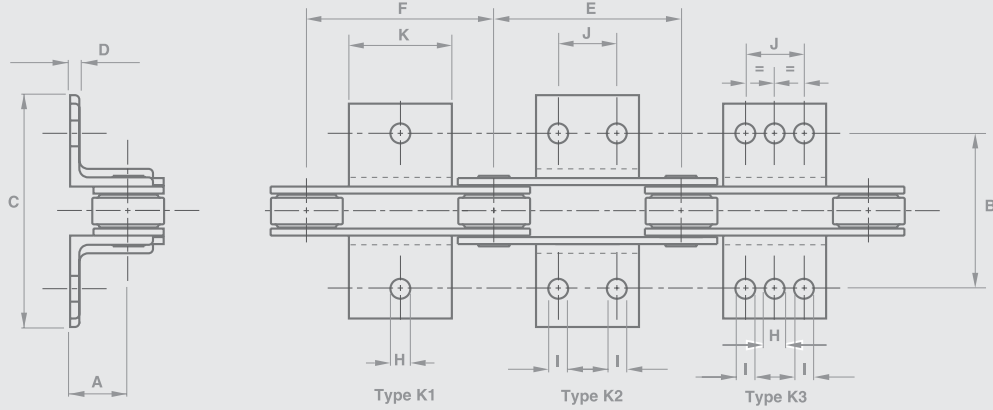

ISO K Attachments (Welded)

Chain Technical Details

Chain No	Breaking Load Newtons	Platform Height	Transverse Pitch	Width Over Attachment Inner/Outer	Attachment Thickness Inner/Outer	Attachment Type	Attachment Minimum Outer Pitch	Attachment Minimum Inner Pitch	Centre Hole Dia	Outer Holes Dia	Attachment Hole Pitch	Platform Length	Mass (kg/Att)
		A	B	C	D		E	F	H	I	J	K	
M40	40000	25	70	104/112	3.5	K1	63	63	9	-	-	20	0.04
						K2	80	80	-	9	20	40	0.07
						K3	100	100	9	9	40	60	0.11
						K3	125	125	9	9	65	85	0.15
M56	56000	30	88	119/129	5.0	K1	63	63	11	-	-	25	0.04
						K2	100	100	-	11	25	50	0.07
						K3	125	125	11	11	50	75	0.11
						K3	160	160	11	11	85	110	0.15
M80	80000	35	96	135/147	5.0	K1	80	80	11	-	-	25	0.10
						K3	125	125	11	11	50	75	0.25
						K3	160	160	11	11	85	110	0.37
						K3	200	200	11	11	125	150	0.50
M112	112000	40	110	151/165	6.0	K1	80	80	14	-	-	30	0.20
						K2	125	125	-	14	35	65	0.35
						K3	160	160	14	14	65	95	0.50
						K3	200	200	14	14	100	130	0.75
M160	160000	45	124	178/195	6.0	K1	100	100	14	-	-	30	0.20
						K2	160	160	-	14	50	80	0.45
						K3	200	200	14	14	85	115	0.65
						K3	250	250	14	14	145	175	0.95
M224	224000	55	140	206/224	8.0	K1	125	125	18	-	-	40	0.30
						K2	200	200	-	18	65	105	0.80
						K3	250	250	18	18	125	165	1.20
						K3	315	315	18	18	190	230	1.65
M315	315000	65	160	216/240	10.0	K1	160	160	18	-	-	35	0.50
						K2	200	200	-	18	50	85	0.85
						K2	250	250	-	18	100	135	1.40
						K2	315	315	-	18	155	190	1.85
M450	450000	75	180	228/255	10.0	K1	200	200	18	-	-	40	0.60
						K2	250	250	-	18	85	125	1.40
						K2	315	315	-	18	155	195	2.40
						K2	400	400	-	18	240	280	3.50
M630	630000	90	230	302/333	12.0	K1	250	250	24	-	-	50	1.30
						K2	315	315	-	24	100	150	3.70
						K2	400	400	-	24	190	240	5.60
						K2	500	500	-	24	300	350	7.50
M900	900000	110	280	358/393	15.0	K1	250	250	30	-	-	60	1.70
						K2	315	315	-	30	65	125	4.80
						K2	400	400	-	30	155	215	7.50
						K2	500	500	-	30	240	300	9.80

Elevator Chain

Heavy Duty Elevator Chain

HEAVY DUTY ELEVATOR CHAIN - 378kN BREAKING LOAD FOR DYNAMIC DISCHARGE ELEVATOR

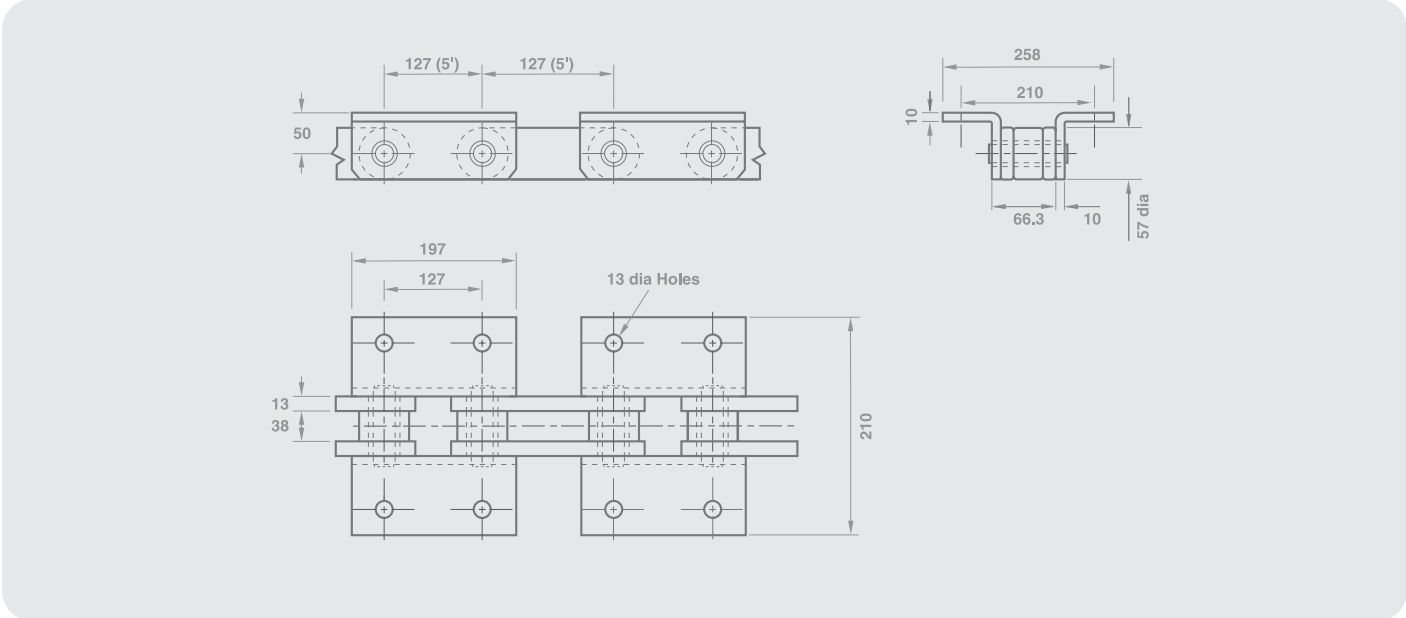

HEAVY DUTY ELEVATOR CHAIN - 711kN BREAKING LOAD FOR POSITIVE DISCHARGE ELEVATOR

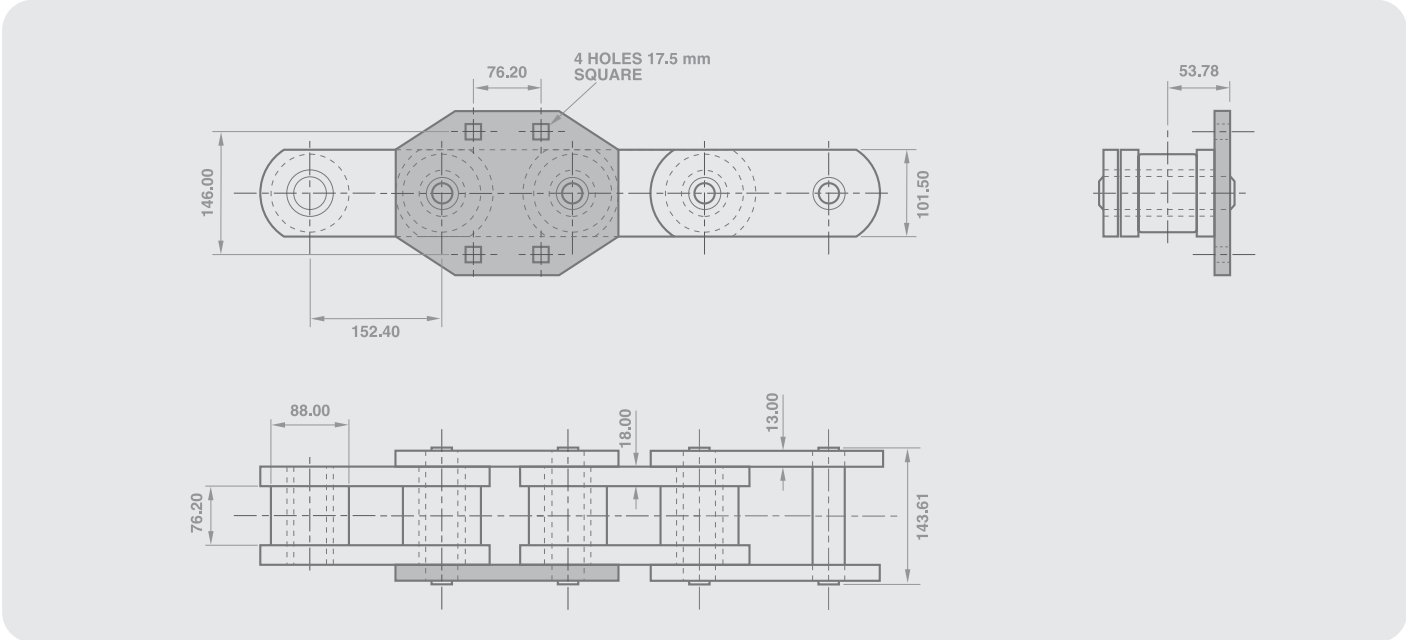

Welded Steel Chain

Type W

Section 1

Permweld chains are normally of cranked link construction. The pins have a press fit into the side plates, thus eliminating unnecessary wear due to pin movement. Accurate punching of the plate, automated machine welding and assembly of the bushes to side plates ensures high quality and dimensional control. Steels of medium carbon grades are used for pin and plates and may be heat treated to produce greater strength and wear resistance. Bushes are of carburizing grades of carbon steel which may be case hardened.

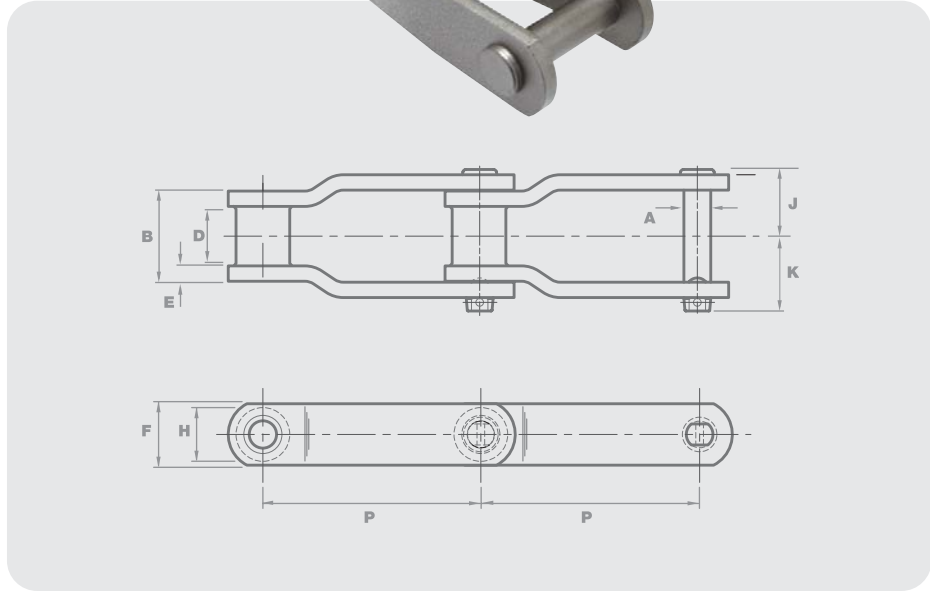
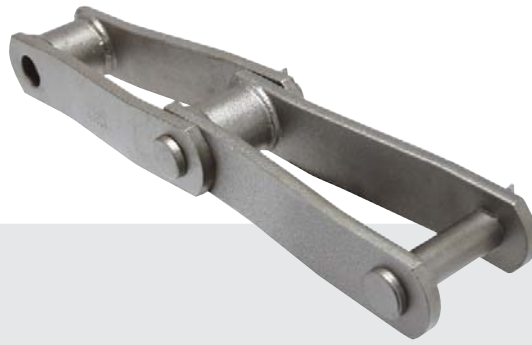

Permweld W
Chain

Technical Details

Chain No	Pitch mm	Pitch inch	Mass kg/m	Average Ultimate Strength N	Pin Diameter	Sprocket Thickness max	Plate Thickness mm	Plate Height mm	Bush Diameter mm	CL to Pin Head mm	CL to Pin End mm	Outside Width at Inner Plate mm
W-78	66.269	2.609	6.251	106762	12.700	28.575	6.350	28.575	22.225	36.116	40.084	50.800
W-78P	66.269	2.609	6.251	133452	12.700	28.575	6.350	28.575	22.225	36.116	40.081	50.800
W-82	78.105	3.075	7.442	115658	14.288	31.750	6.350	31.750	26.988	38.497	43.259	57.150
W-82P	78.105	3.075	7.442	155694	14.288	31.750	6.350	31.750	26.988	38.506	43.256	57.150
W-82XHD	78.105	3.075	13.097	204626	19.050	31.750	9.525	38.100	34.925	45.641	53.578	63.500
W-106	152.400	6.000	9.972	164591	19.050	41.275	9.525	38.100	34.925	49.609	56.753	71.438
W-106P	152.400	6.000	9.972	260231	19.050	41.275	9.525	38.100	34.925	49.606	56.744	71.450
W-106HD	152.400	6.000	12.204	222420	19.050	41.275	12.700	38.100	31.750	56.356	63.500	77.788
W-110	152.400	6.000	9.674	204626	19.050	47.625	9.525	38.100	31.750	51.991	59.134	76.200
W-110P	152.400	6.000	9.674	266904	19.050	47.625	9.525	38.100	36.513	51.994	59.131	76.200
W-111	120.900	4.760	12.204	204626	19.050	57.150	9.525	38.100	36.513	56.753	63.897	85.725
W-111P	120.900	4.760	12.204	266904	19.050	57.150	9.525	38.100	41.275	56.744	63.907	85.725
W-124	101.600	4.000	12.353	204626	19.050	41.275	9.525	38.100	41.275	49.606	56.744	71.438
W-124P	101.600	4.000	12.353	266904	19.050	41.275	9.525	38.100	41.275	49.606	56.744	71.450
W-124HD	103.200	4.063	20.241	373665	22.225	41.275	12.700	50.800	41.275	55.959	62.706	76.200
W-124HDP	103.200	4.063	20.241	400356	22.225	41.275	12.700	50.800	41.275	55.956	62.713	76.200
W-132	153.670	6.050	19.497	373665	25.400	73.025	12.700	50.800	41.275	74.216	82.550	111.125
W-132P	153.670	6.050	19.497	444840	25.400	73.025	12.700	50.800	41.275	74.219	82.550	111.125
W-132HD	153.670	6.050	22.920	467082	25.400	73.025	15.875	50.800	41.275	80.566	88.900	117.475
W-132HDP	153.670	6.050	22.920	533808	25.400	73.025	15.875	50.800	41.275	80.569	88.900	117.475
W-134	103.200	4.063	24.855	458185	25.400	41.275	12.700	63.500	41.275	56.744	62.706	76.200
W-134P	103.200	4.063	24.855	498221	25.400	41.275	12.700	63.500	41.275	56.744	62.713	76.200
WS-150	153.670	6.050	23.515	373665	25.400	73.025	12.700	63.500	44.450	74.219	82.550	111.125
WS-150P	153.670	6.050	23.515	444840	25.400	73.025	12.700	63.500	44.450	74.219	82.550	111.125
WS-157	153.670	6.050	29.022	556050	28.575	69.850	15.875	63.500	44.450	80.963	92.075	117.475
WS-157P	153.670	6.050	29.022	622776	28.575	69.850	15.875	63.500	44.450	80.975	92.075	117.475
W-182	78.105	3.075	12.353	204626	19.050	28.575	9.525	38.100	34.925	42.466	50.403	57.150
WS-784	101.600	4.000	4.911	106762	12.700	28.575	6.350	28.575	22.225	36.119	40.081	50.800
WS-784P	101.600	4.000	4.911	133452	12.700	28.575	6.350	28.575	22.225	36.119	40.081	50.800
WS-855PB	153.670	6.050	27.534	667260	28.575	69.850	14.288	63.500	44.450	76.994	89.694	112.713

Welded Steel Chain

Type WD

Type WD Permaweld drag chains are furnished with heat treated pins and formed steel bushes. The bushes are shaped to provide maximum conveying capacity, shock resistance, toughness and higher yield strength in bending than many comparable cast and other welded links. Precise press fits of the pins in the side plates and single flats milled on the pin ends prevent unnecessary wear due to pin movement.

Pins and side plates are made of medium carbon steels. Bushes are of carburizing grade steels which are case hardened on the heat treated chains. Accurately punched holes and assembly procedures ensure dimensional control. The flexibility of welded construction provides a wider range of attachment links than is normally offered for similar cast chains.

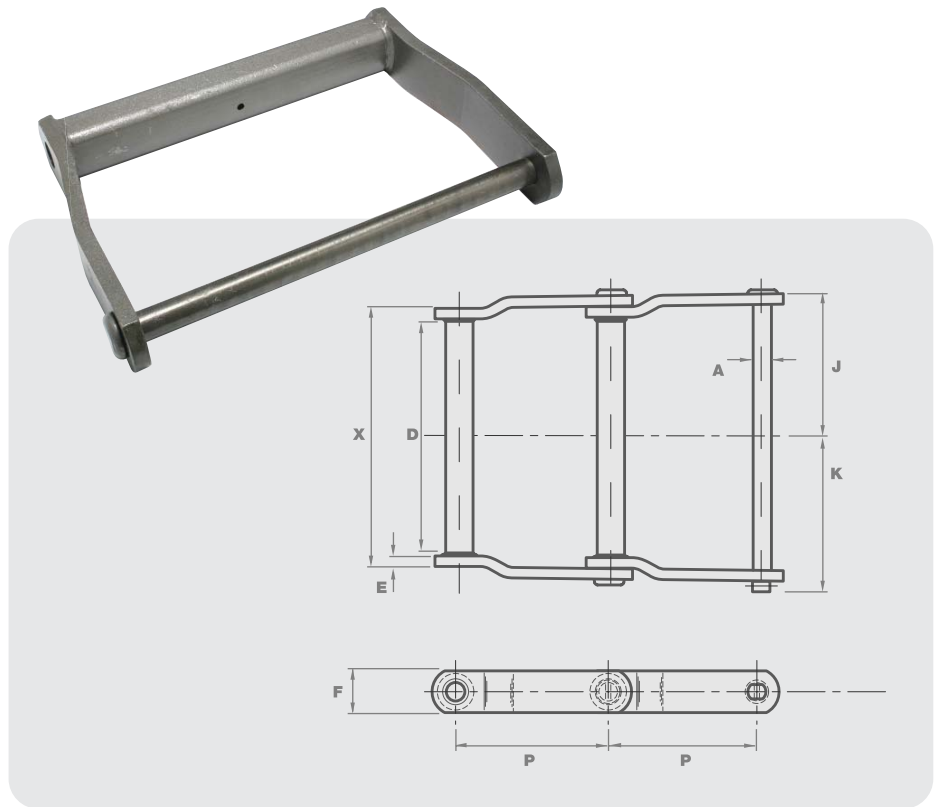

Permaweld WD

Chain

Technical Details

Chain No	Pitch mm	Pitch inch	Mass kg/m	Average Ultimate Strength N	Pin Diameter	Sprocket Thickness max	Plate Thickness mm	Plate Height mm	CL to Pin Head	CL to Pin End	Outside Width at Inner Plate
WD-102	127.0	5.0	15.478	226868	19.050	161.925	9.525	38.100	113.903	121.047	196.850
WD-102P	127.0	5.0	15.478	266904	19.050	161.925	9.525	38.100	113.894	121.057	196.850
WD-104	76.2	3.0	11.758	226868	19.050	104.775	9.525	38.100	83.741	90.885	136.525
WD-104P	76.2	3.0	11.758	266904	19.050	104.775	9.525	38.100	83.744	90.881	136.525
WD-110	76.2	3.0	16.074	226868	19.050	228.600	9.525	38.100	147.241	154.385	263.526
WD-110P	76.2	3.0	16.074	266904	19.050	228.600	9.525	38.100	147.244	154.382	263.526
WD-112	203.2	8.0	13.544	226868	19.050	228.600	9.525	38.100	147.241	154.385	263.526
WD-112P	203.2	8.0	13.544	266904	19.050	228.600	9.525	38.100	147.244	154.382	263.526
WD-116	203.2	8.0	20.985	226868	19.050	330.201	9.525	44.450	194.866	202.010	358.776
WD-116P	203.2	8.0	20.985	306940	19.050	330.201	9.525	44.450	194.869	202.007	358.776
WD-120	152.4	6.0	26.939	311388	22.225	222.250	12.700	50.800	150.019	156.369	260.351
WD-120P	152.4	6.0	26.939	400356	22.225	222.250	12.700	50.800	150.013	156.363	260.351
WD-122	203.2	8.0	22.771	311388	22.225	222.250	12.700	50.800	150.013	156.369	260.351
WD-122P	203.2	8.0	22.771	400356	22.225	222.250	12.700	50.800	150.013	156.363	260.351
WD-480	203.2	8.0	25.450	311388	22.225	282.576	12.700	50.800	181.769	188.119	323.851
WD-480P	203.2	8.0	25.450	400356	22.225	282.576	12.700	50.800	181.763	188.113	323.851
WD-480HP	203.2	8.0	27.980	449288	25.400	282.576	12.700	50.800	181.763	188.113	323.851
WD-480XHD	203.2	8.0	31.255	378114	25.400	282.576	15.875	50.800	188.119	194.469	330.201
WD-480XDHP	203.2	8.0	31.255	542705	25.400	282.576	15.875	50.800	188.113	194.463	330.201

Agricultural Chain Range

ISO 487

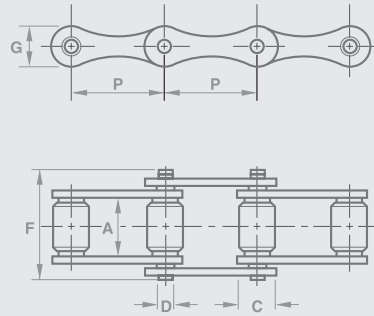

ISO 487 Chain

Chain Technical Details

Chain Number	Pitch Inch	Inside Width	Roller Dia	Pin Dia	Over Pin	Plate Height	Breaking Load kN
	P	A	C	D	F	G	
S32	1.15	15.90	11.40	4.47	26.70	13.50	20.0
S42	1.375	19.10	14.27	7.01	34.30	19.80	42.3
S45	1.63	22.23	15.20	5.74	38.10	17.30	32.9
S52	1.50	22.23	15.20	5.74	38.10	17.30	32.9
S55	1.63	22.23	17.80	5.74	38.10	17.30	32.9
S62	1.65	25.40	19.10	5.74	40.60	17.30	34.7
S77	2.297	22.23	18.30	8.92	43.20	26.20	56.1
S88	2.609	28.60	22.90	8.92	50.80	26.20	56.1
CA550	1.63	19.81	16.70	7.19	36.00	19.30	45.0

All chains are electroless nickel plated

Agricultural Chain Range

K Attachment and M Attachment

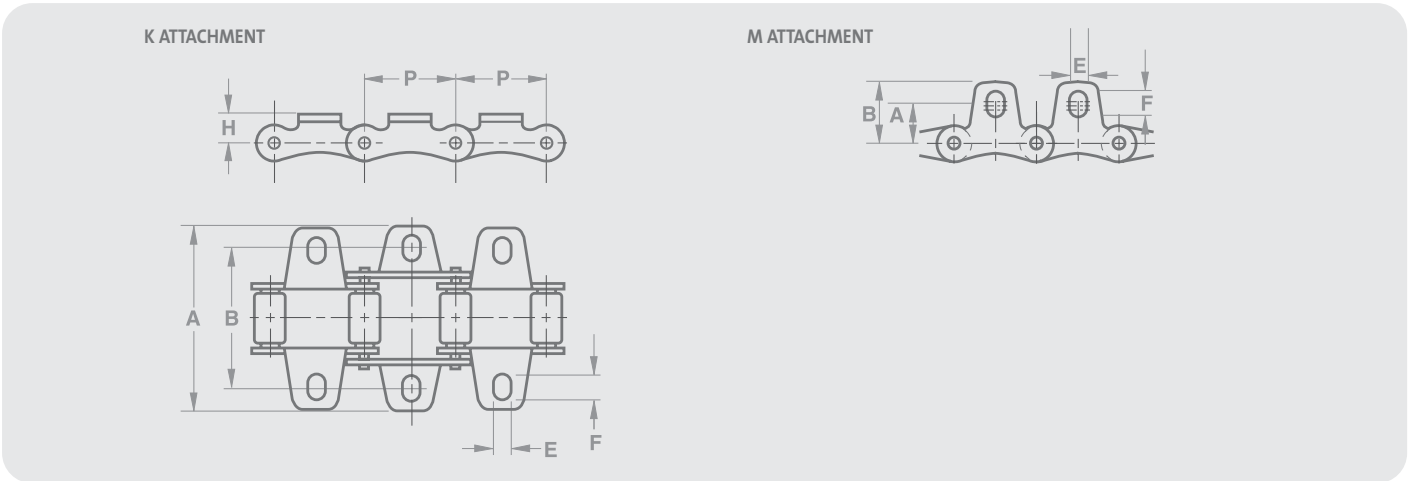

K Attachments

Chain

Technical Details

Chain No	Transverse Pitch	Overall Width	Platform Height	Hole Width	Hole Length
	B	A	H	E	F
S32	42.9	60.0	8.6	6.5	8.1
S42	54.0	74.0	14.0	8.3	12.5
S45	54.0	74.0	11.4	8.3	11.5
S52	58.8	77.2	11.4	8.5	10.0
S55	54.0	74.0	11.4	8.3	11.5
S62	66.6	95.0	11.4	8.5	14.8
S77	76.2	101.0	20.8	8.5	11.5
S88	96.8	119.0	20.8	8.5	10.0
CA550	54.0	71.4	12.7	8.35	11.5

M Attachments

Chain

Technical Details

Chain No	Attachment Height	Hole Centre	Hole Width	Hole Length
	B	A	E	F
S32	26.0	17.3	6.5	6.9
S42	34.1	23.6	8.3	11.5
S45	30.0	19.8	8.3	11.5
S52	31.6	22.1	8.5	10.0
S55	30.0	19.8	8.3	11.5
S62	38.1	24.6	8.5	14.7
S77	49.8	36.3	8.5	11.5
S88	55.4	43.7	8.5	10.0

Agricultural Chain

Standard Sprockets

Section 1

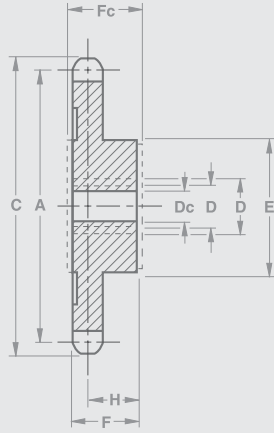

For Chain No. S32

No. of Teeth	Part No	P.C.D.	Top Dia	BORE Stock Cast	BORE Min. Machined	BORE Max. Machined	BOSS Dia	BOSS Length Cast	BOSS Length Machined	Chain € from Boss Face when Machined	Weight (Cast Bore) kg
		A	C	Dc	D	D	E	Fc	F	H	
9	281063*	85.39	94	-	-	38	64	41	38	31.0	1.13
10	281064*	94.51	103	-	-	38	70	41	38	31.0	1.36
11	281065*	103.68	113	-	-	38	70	41	38	31.0	1.47
12	281066*	112.85	122	-	-	38	70	41	38	31.0	1.59
14	281068*	131.27	140	-	-	45	76	41	38	31.0	2.15
15	281069*	140.49	149	-	-	45	76	41	38	31.0	2.38
16	281070*	149.73	159	-	-	45	76	41	38	31.0	2.49
18	281072	168.22	177	-	-	45	76	41	38	31.0	2.61
27	281078	251.61	261	19	24	50	89	51	44	32.0	4.54
30	281080	279.45	288	19	24	50	89	51	44	32.0	4.99
34	281082	316.59	325	19	24	50	89	51	44	32.0	5.44

For Chain No. S52

9	281123*	111.40	125	-	-	48	83	54	51	41.0	2.38
10	281124*	123.39	136	-	-	50	89	54	51	41.0	2.84
11	281125*	135.23	148	-	-	50	89	54	51	41.0	3.29
12	281126*	147.22	161	-	-	50	89	54	51	41.0	3.63
13	281127*	159.21	172	-	-	50	89	54	51	41.0	4.08
14	281128*	171.22	184	-	-	60	102	54	51	41.0	4.99
15	281129*	183.26	197	-	-	60	102	54	51	41.0	5.44
16	281130	195.30	209	19	24	60	102	57	51	41.0	5.44
17	281131	207.34	220	19	24	60	102	57	51	41.0	5.67
18	281132	219.41	233	19	24	60	102	57	51	41.0	5.90
27	281138	328.19	341	24	28	65	108	64	57	41.5	9.07
30	281140	364.49	378	24	28	65	108	64	57	41.5	9.98
34	281142	412.93	426	24	28	70	121	64	57	41.5	13.15

For Chain No. S45

9	281093*	121.06	134	-	-	50	89	54	51	41.0	2.95
10	281094*	133.99	147	-	-	50	89	54	51	41.0	3.29
12	281096*	159.97	173	-	-	50	89	54	51	41.0	4.08
15	281099	199.14	212	19	24	60	102	57	51	41.0	5.44
18	281102	238.43	252	19	24	60	102	57	51	41.0	6.58
27	281108	356.62	370	24	28	65	108	64	57	41.5	9.98
30	281110	396.09	409	24	28	65	108	64	57	41.5	10.89
34	281112	448.72	462	24	28	70	121	70	64	48.0	14.51

* SMALL SOLID SPROCKETS.
OTHER SPROCKETS AVAILABLE ON REQUEST.

SPROCKETS CAN BE MODIFIED ON REQUEST. WHEN KEYWAYS ARE REQUESTED, LARGE SPROCKETS ARE FACED BOTH SIDES OF THE BOSS - SMALL SOLID SPROCKETS ARE FACED ON BOSS SIDE ONLY.
SPROCKETS FOR OTHER SIZES OF CHAIN - DETAILS ON REQUEST.

Agricultural Chain

Standard Sprockets

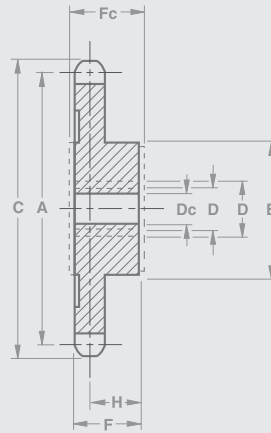

For Chain No. S62

No. of Teeth	Part No	P.C.D.	Top Dia	BORE Stock Cast	BORE Min. Machined	BORE Max. Machined	BOSS Dia	BOSS Length Cast	BOSS Length Machined	Chain ϵ from Boss Face when Machined	Weight (Cast Bore) kg
		A	C	Dc	D	D	E	Fc	F	H	
9	281153*	122.53	135	-	-	50	89	60	57	46.0	3.29
10	281154*	135.64	149	-	-	60	102	60	57	46.0	4.31
11	281155*	148.77	162	-	-	60	102	60	57	46.0	4.99
12	281156*	161.93	175	-	-	60	102	60	57	46.0	5.44
13	281157*	175.13	188	-	-	60	102	60	57	46.0	6.12
14	281158*	188.34	201	-	-	65	108	60	57	46.0	6.58
15	281159	201.57	215	19	24	65	108	64	57	46.0	7.03
16	281160	214.83	228	19	24	65	108	64	57	46.0	7.26
17	281161	228.09	241	19	24	65	108	64	57	46.0	7.71
18	281162	241.35	254	19	24	65	108	64	57	46.0	8.16
27	281168	361.01	374	24	28	70	121	70	64	46.5	12.70
30	281170	400.94	414	24	28	70	121	70	64	46.5	14.06
34	281172	454.23	467	24	28	75	133	76	70	53.0	19.05

* SMALL SOLID SPROCKETS.
OTHER SPROCKETS AVAILABLE ON REQUEST.

SPROCKETS CAN BE MODIFIED ON REQUEST. WHEN KEYWAYS ARE REQUESTED, LARGE SPROCKETS ARE FACED BOTH SIDES OF THE BOSS - SMALL SOLID SPROCKETS ARE FACED ON BOSS SIDE ONLY.
SPROCKETS FOR OTHER SIZES OF CHAIN - DETAILS ON REQUEST.

Section 2

Conveyor Sprocket Details

Standard Conveyor Sprockets

To Suit BS4116 Part 4

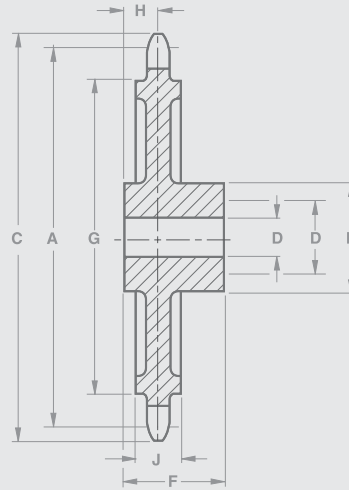

3000 lbf, 13000 Newtons Breaking Load

Sprockets

Technical Details

Pitch Inch	mm	No. of Teeth	Renold Part No.	PCD	Top Dia	Shroud Dia	Shroud Width	Bore Dia Min	Bore Dia Max	Boss Dia	ϕ of Tooth to End Face*	Distance Through*	Weight Approx
				A	C	G	J	D	D	E	H	F	kg

12.1mm Diameter Roller

1.5	38.1	8	208121#	99.57	109	-	-	16	32	57	9.5	38	0.9
		12	208125#	147.22	157	-	-	16	38	76	9.5	45	2.0
2.0	50.8	8	208212#	132.74	142	-	-	24	38	76	9.5	45	1.8
		12	208216#	196.27	207	156	19	24	45	89	9.5	51	3.9
3.0	76.2	8	208391#	199.11	208	150	19	24	45	89	9.5	51	3.7
		12	208395#	294.41	305	250	19	24	45	89	9.5	51	7.9

25.4mm Diameter Roller

1.5	38.1	8	208151##	99.57	105	-	-	16	32	57	9.5	38	0.9
		12	208155##	147.22	157	-	-	16	38	76	9.5	45	2.0
2.0	50.8	8	208241##	132.74	142	-	-	24	38	76	9.5	45	1.8
		12	208245##	196.27	207	156	19	24	45	89	9.5	51	3.9
3.0	76.2	8	208422##	199.11	208	150	19	24	45	89	9.5	51	3.7
		12	208426##	294.41	306	250	19	24	45	89	9.5	51	7.9
4.0	101.6	8	208501##	265.51	274	212	19	24	45	89	9.5	51	7.0
		12	208505##	392.56	404	345	19	24	50	102	9.5	64	12.2

SPROCKETS WITH CUT TEETH ## SPROCKETS WITH CAST TEETH

* AFTER MACHINE FACING THE BOSS

Standard Conveyor Sprockets

To Suit BS4116 Part 4

Section 2

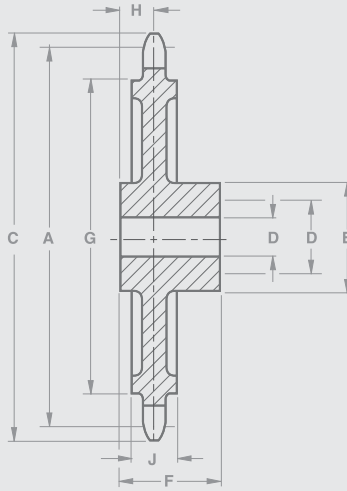

4500 lbf, 20000 Newtons Breaking Load

Sprockets

Technical Details

Pitch Inch	mm	No. of Teeth	Renold Part No.	PCD	Top Dia	Shroud Dia	Shroud Width	Bore Dia Min	Bore Dia Max	Boss Dia	☉ of Tooth to End Face*	Distance Through*	Weight Approx
				A	C	G	J	D	D	E	H	F	kg

25.4mm Diameter Roller

1.5	38.1	8	208151##	99.57	105	-	-	16	32	57	9.5	38	0.9
		12	208155##	147.22	157	-	-	16	38	76	9.5	45	2.0
2.0	50.8	8	208241##	132.74	142	-	-	24	38	76	9.5	45	1.8
		12	208245##	196.27	207	156	19	24	45	89	9.5	51	3.9
3.0	76.2	8	208422##	199.11	208	150	19	24	45	89	9.5	51	3.7
		12	208426##	294.41	306	250	19	24	45	89	9.5	51	7.9

6000 lbf, 27000 Newtons and 7500 lbf, 33000 Newtons Breaking Load

Sprockets

Technical Details

Pitch Inch	mm	No. of Teeth	Renold Part No.	PCD	Top Dia	Shroud Dia	Shroud Width	Bore Dia Min	Bore Dia Max	Boss Dia	☉ of Tooth to End Face*	Distance Through*	Weight Approx
				A	C	G	J	D	D	E	H	F	kg
2.0	50.8	8	200121##	132.74	144	-	-	24	38	76	12.5	51	2.3
		12	200125##	196.27	212	-	-	24	50	102	12.5	51	5.4
3.0	76.2	8	200302##	199.11	215	-	-	24	50	102	12.5	51	5.4
		10	200304##	246.58	264	193	25	28	65	114	12.5	64	8.6
		12	200306##	294.41	314	243	25	28	65	114	12.5	64	10.0
4.0	101.6	8	200392##	265.51	281	204	25	35	65	114	12.5	64	8.6
		10	200394##	328.78	347	272	25	35	65	114	12.5	64	13.8
		12	200396##	392.56	411	338	25	38	70	127	12.5	70	16.1
6.0	152.4	8	200571##	398.25	414	326	25	38	70	127	12.5	70	19.7
		12	200575##	588.82	608	527	25	38	75	133	12.5	76	34.2

SPROCKETS WITH CAST TEETH

* AFTER MACHINE FACING THE BOSS

Standard Conveyor Sprockets

To Suit BS4116 Part 4

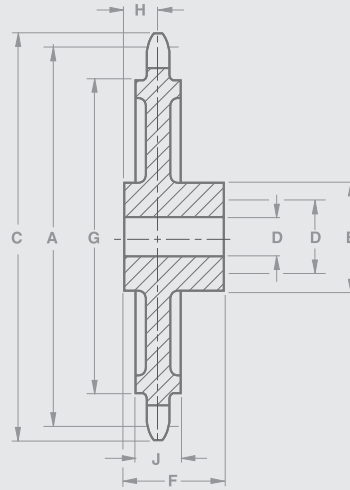

12000 lbf, 54000 Newtons and
15000 lbf, 67000 Newtons Breaking Load

Sprockets

Technical Details

Pitch Inch	mm	No. of Teeth	Renold Part No.	PCD	Top Dia	Shroud Dia	Shroud Width	Bore Dia Min	Bore Dia Max	Boss Dia	€ of Tooth to End Face*	Distance Through*	Weight Approx
				A	C	G	J	D	D	E	H	F	kg
3.0	76.2	8	201211##	199.11	218	-	-	38	70	114	16	70	8.4
		12	201215##	294.41	318	230	32	38	75	133	16	76	15.0
4.0	101.6	8	201301##	265.51	286	192	32	38	70	127	16	70	10.9
		12	201305##	392.56	415	325	32	48	80	140	16	76	20.2
6.0	152.4	8	201481##	398.25	418	314	32	48	80	140	16	76	21.5
		12	201485##	588.82	612	514	32	48	90	165	16	89	41.3

24000 lbf, 107000 Newtons and
30000 lbf, 134000 Newtons Breaking Load

Sprockets

Technical Details

Pitch Inch	mm	No. of Teeth	Renold Part No.	PCD	Top Dia	Shroud Dia	Shroud Width	Bore Dia Min	Bore Dia Max	Boss Dia	€ of Tooth to End Face*	Distance Through*	Weight Approx
				A	C	G	J	D	D	E	H	F	kg
4.0	101.6	8	202121##	265.51	290	-	-	48	85	152	19	83	16.6
		12	202125##	392.56	420	312	38	55	95	165	19	95	31.3
6.0	152.4	8	202301##	398.25	423	301	38	55	95	165	19	95	32.2
		12	202305##	588.82	617	502	38	60	110	196	19	130	63.0

SPROCKETS WITH CAST TEETH

* AFTER MACHINE FACING THE BOSS