



## SERIE BMBM

CARATTERISTICHE TECNICHE

BMBM series consist of three phase asynchronous brake motors with twin brakes working independently of each other, on frame sizes from 71 mm up to 200 mm and power from 0,18 kW up to 37 kW.

BMBM series main feature is a very high reliability level in those lifting applications where there are high demands of safety and quiet. For these reasons BMBM series motors are particularly suitable to be used for TV-cine studios and theatre's stages. The motor brakes in case of power supply failure. The braking action is obtained without axial shaft sliding and it provides an equal braking torque in both running directions. The brake components and assembly are designed with special features to be noiseless during stops, granting the high ratings of EN81.

The manual brake release is made up of two levers (one for each brake) in the way to avoid unwanted starts. It's possible to release the brake using just one hand.

The two brakes are supplied through independent rectifiers which are positioned in the terminal box.

Rectifiers are provided with an overvoltage protection device and with an EMC filter. It's possible to have two types of wirings connection to the rectifier for each brake, in relation to the intervention time required.

All BMBM series motors are suitable for inverter use; On request it's possible to have the motor with a built-in encoder or to have the motor ready for the encoder to be easily mounted.

The brake disks friction material is asbestos free and the brake lining has an high friction factor and is long-lasting.

The winding insulation class is F. Class H is available upon request. Motor construction type is totally enclosed not vented with IP 54 protection degree (IP 55 and external cooling are available upon request).

BMBM series motors tolerate an heavy overload level and working without external cooling have to be used on intermittent duty only.

On request it's possible to provide motors with thermo-protection devices.

Frame is made of die cast, light metal on motors up to 132 frame size and of cast iron on motors from 160 up to 200 frame size. Foot is integrated in the frame to make the whole motor more solid since the applications in which these motors are used are critical.

Plates and flanges are made of aluminium up to 90 frame size and of cast iron for bigger frame size.

Available powers and pole are the same as the BA series (please refer to the MGM brake motors general catalogue).





SERIE BMBM

**DIMENSIONS**

Tipo	71	80	90S	90L	100	112	132S	132M	160M	160L	180L	200
A	112	125	140	140	160	190	216	216	254	254	279	316
B	90	100	100	125	140	140	140	178	210	254	279	305
C	45	50	56	56	63	70	89	89	108	108	121	133
D	14	19	24	24	28	28	38	38	42	42	48	55
d	M5	M6	M8	M8	M10	M10	M12	M12	M16	M16	M16	M16
E	30	40	50	50	60	60	80	80	110	110	110	110
Fa	9.5	11.5	11.5	11.5	14	14	14	14	18	18	18	18
Fb	M6	M6	M8	M8	M8	M8	M10	M10				
f	5	6	8	8	8	8	10	10	12	12	14	16
g	11	15.5	20	20	24	24	33	33	37	37	42.5	49
H	71	80	90	90	100	112	132	132	160	160	180	200
h	5	6	7	7	7	7	8	8	8	8	9	10
I	7	9	10	10	12	12	12	12	14	14	14	18
L1	180	194	207	232	254	262	248	260	314	337	399	424
Ma	130	165	165	165	215	215	265	265	300	300	300	350
Mb	85	100	115	115	130	130	165	165				
Na	110	130	130	130	180	180	230	230	250	250	250	300
Nb	70	80	95	95	110	110	130	130				
Oa	3.5	3.5	3.5	3.5	4	4	4	4	5	5	5	5
Ob	2.5	3	3	3	3.5	3.5	3.5	3.5				
Pa	160	200	200	200	250	250	300	300	350	350	350	400
Pb	105	120	140	140	160	160	200	200				
Q	303	342	380	405	456	491	567	605	719	763	832	873
R1	135	135	170	170	170	170	180	180	260	260	260	260
S	10	12	12	12	14	14	14	14	15	15	15	18
V	8.5	9.5	10.5	10.5	13	13.5	18	18	18	18	21	21
W1	120	131	148	148	162	176	196	196	267	267	277	277
Y	85	105	130	130	150	170	195	195	225	225	258	306
Z1	86	86	112	112	112	112	120	120	184	184	184	184

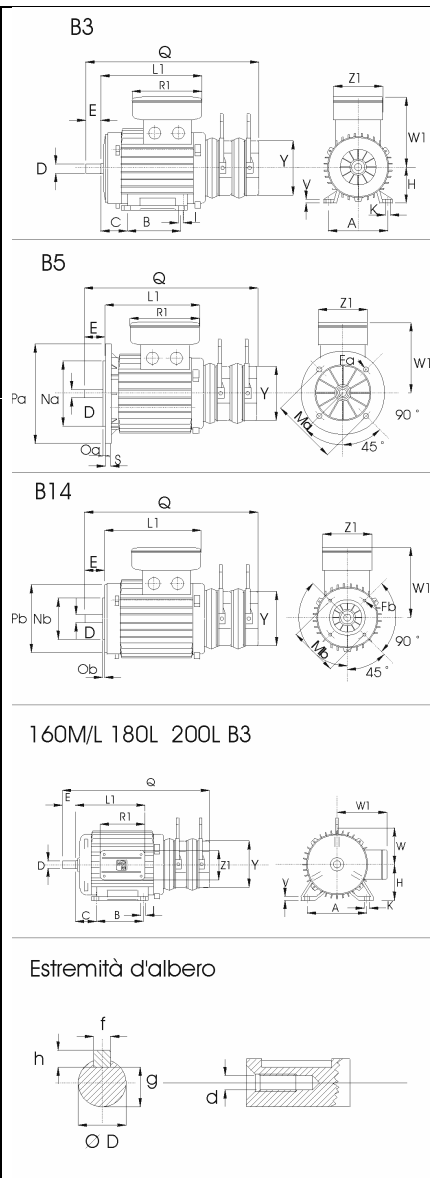

I dati riportati sul presente catalogo non sono impegnativi, essendi suscettibili di variazioni in ogni momento senza preavviso - cod. rif. A2410002

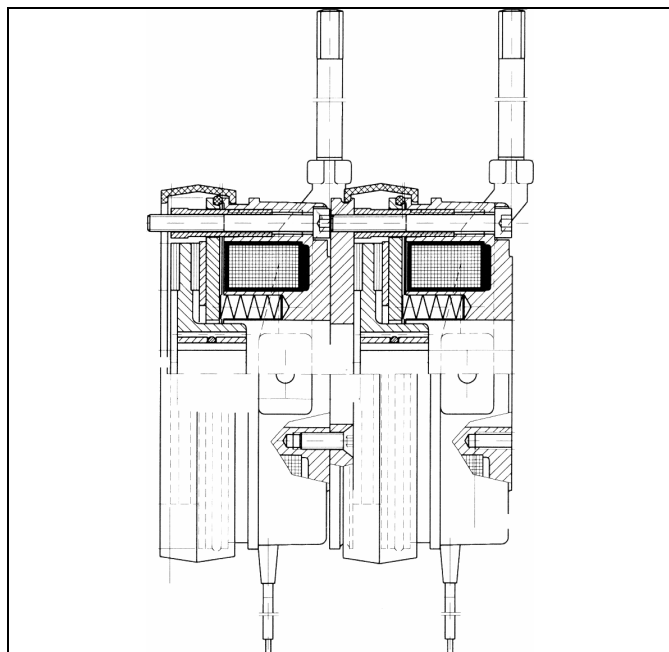

**TECHNICAL CHARACTERISTICS**

Frame size (mm)	Brake torque (Nm)	Power (W)
71	2 x 3,5	22
80	2 x 7,0	28
90	2 x 14	34
100	2 x 28	42
112	2 x 42	50
132	2 x 70	64
160	2 x 107	76
180	2 x 187	100
200	2 x 300	140